

Bit Error Rate (BER) Comparison of AWGN Channels for Different Type's Digital Modulation Using MATLAB Simulink

Md. Golam Sadeque*

Lecturer, Dept. of EEE, PUST, Bangladesh

Email: golamsadeq@gmail.com

Abstract

The MATLAB software with relevant Toolboxes for developing Simulink model is used for the simulation of system. In this paper, three basic types of digital modulation techniques are discussed then the bit error rate performance characteristics of receiver are evaluated by using MATLAB Simulink model for FSK, PSK and QAM modulation techniques. There are various kinds of channel used in wireless communication. In this paper, the AWGN channel is used between transmitter and receiver. This paper focuses on the characterization and the design of analog signal waveforms that carry digital information and compares their performance on an AWGN channel.

Keywords: AWGN channel; BER; FSK; PSK; QAM.

1. Introduction

In the recent times for fast growing wireless technologies, the performance of the transmitting and receiving systems is very important. A tremendous technological development during the previous two decades has provided a potential growth in the field of digital communication and lot of latest applications and technologies are coming up everyday due to valid reason [8]. Digital modulation schemes contribute to the evolution of mobile communications by increasing the capacity, speed as well as the quality of the wireless network [8]. Digital modulation schemes provide more information carrying capacity, better quality communication, data security and RF spectrum sharing to accommodate more services [14]. So we have to analyze the parameters, component, and structures of the channels [6].

* Corresponding author.

E-mail address: golamsadeq@gmail.com.

The bit-error rate is the main performance parameter of a digital communication system [12]. The performance of channel can be evaluated from bit error rate (BER) versus signal to noise ratio (SNR) curve. Noise means unwanted energy. Noise may interfere the signal at any point in communication system which will affect when signal is weak [13]. In the study of communication systems the classical (ideal) additive white Gaussian noise (AWGN) channel, with statistically independent Gaussian noise samples corrupting data samples free of inter-symbol interference (ISI), is the usual starting point for understanding basic performance relationships [1]. The primary source of performance degradation is thermal noise generated in the receiver [1]. The thermal noise usually has a flat power spectral density over the signal band and a zero-mean Gaussian voltage probability density function (pdf) [1].

2. AWGN Channel

Channel is the most important issue for any kind of communication system. Communication channel performance depends on noise. Additive white Gaussian Noise comes from many natural sources such as vibration of atoms in conductor, shot noise, radiation from earth and other warm object and from celestial sources such as the Sun. There are various kinds of communication channel. AWGN channel is the simplest model of a channel and is well suited for wired communication. This channel is linear and time-invariant (LTI). AWGN channel adds white Gaussian noise to the signal when signal passes through it. This channel's amplitude frequency response is flat and phase response is linear for all frequencies [5]. The modulated signals pass through it without any amplitude loss and phase distortion. So in such case, fading does not exist but the only distortion that exists is introduced by the AWGN. The received signal is simplified to

$$r(t) = x(t) + n(t) \dots \dots (1)$$

Where, $n(t)$ represents the noise, has Gaussian distribution with 0 mean and variance as the Noise power and $x(t)$ represent transmitted signal.

3. Bit Error Rate

In a digital transmission, BER is the number of bits with errors divided by the total number of bits that have been transmitted, received or processed over a given time period. That is

$$BER = \frac{\text{Number of bits with error}}{\text{total number of bits sent}}$$

Bit error rate is a key parameter that is used in assessing the systems performance that transmits digital data from one location to another. When data is transmitted over a data link, there is a possibility of errors being introduced into the system [10]. As a result, it is necessary to assess the performance of the system, and BER provides an ideal way in which this can be achieved. BER assesses performance of a system including the transmitter, receiver and the medium between the two.

4. Digital modulation

There are three basic types of modulation methods for transmission of digital signal. The methods are based on three attributes of a sinusoidal signal, amplitude, frequency and phase. The corresponding digital modulation methods are: amplitude shift keying (ASK), frequency shift keying (FSK) and phase shift keying (PSK).

4.1. Amplitude shift keying (ASK)

Amplitude shift keying (ASK) is the simple form of digital modulation. Digital input is unipolar NRZ signal. In ASK carrier amplitude is multiplied by high amplitude for binary “1” or by low amplitude for a binary “0”. However, when the low amplitude is 0 for binary “0” then the ASK is called On-Off keying or OOK which shown in Figure 1. In OOK the amplitude modulated carrier signal can be written as

$$v(t) = A \sin(2\pi f_c t) \dots \dots \dots (2)$$

Where, f_c is the carrier frequency and A is the data bit variable. The value of A can be “1” or “0” depending on the state of the digital input signal.

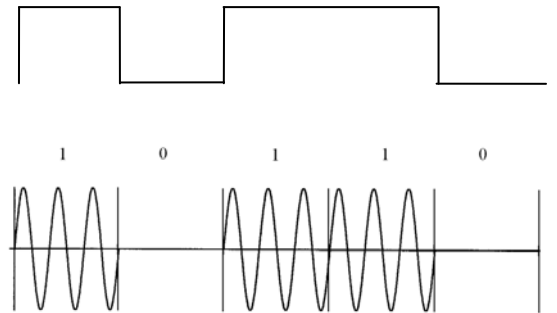

Figure 1: Amplitude shift keying (ASK)

4.2. Frequency shift keying (FSK)

In frequency shift keying (FSK), the frequency of the carrier is shifted between two discrete values, one representing binary “1” and representing binary “0” but the carrier amplitude does not changes. The simple form of FSK is BFSK. The instantaneous vale of the FSK signal is given by

$$v(t) = A \sin(2\pi f_1 t) + \bar{A} \sin(2\pi f_2 t) \dots \dots (3)$$

Where, f_1 and f_2 are the frequencies corresponding to binary “1” and “0” respectively and $f_1 > f_2$. From above equation, it is clear that the FSK signal can be considered to be comprising of two ASK signal with carrier frequencies f_1 and f_2 .

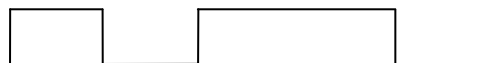

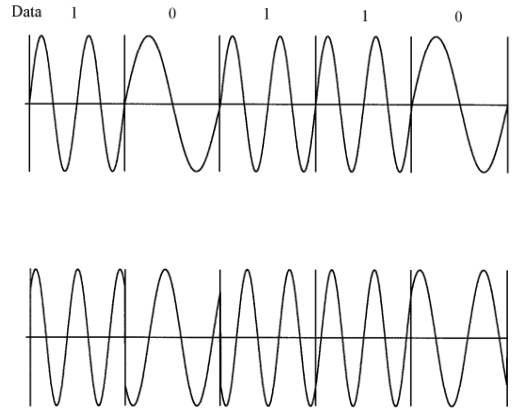

Figure 2: FSK with continuous and discontinuous phase

4.3. Phase shift keying (PSK)

In Phase shift keying (PSK), the phase of the carrier is modulated to represent the binary values. The carrier phase change between 0 and π by the bipolar digital signal. Binary states “1” and “0” are represented by the positive and negative polarity of the digital signal. The simplest form of PSK is BPSK is shown in Figure 2. The instantaneous value of the digital signal can be written as

$$v(t) = A \sin(2\pi f_c t) \dots \dots (4)$$

Where, $A = \pm 1$; $A = 1$ for binary state “1” and $A = -1$ for binary state “0”.

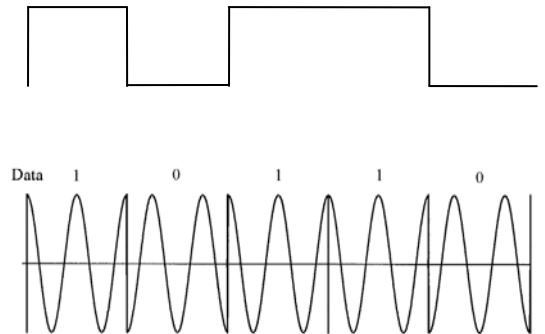

Figure 3: Phase shift keying (PSK)

5. Performance Analysis using MATLAB Simulink

MATLAB simulation model consists of transmitter, channel and receiver. The AWGN channel is used between transmitter and receiver. At the transmitter end data is generated by Bernoulli data generator. Bernoulli data generator generates data with probability a zero 0.5 and sample time one second. The bit error rate (BER) of different types of digital modulation can be calculated through Monte Carlo simulations using MATLAB Simulink file.

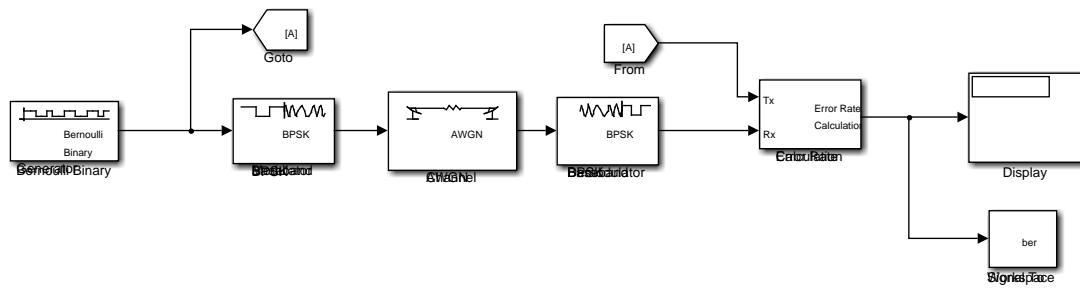

Figure 4: Simulink Model for BPSK

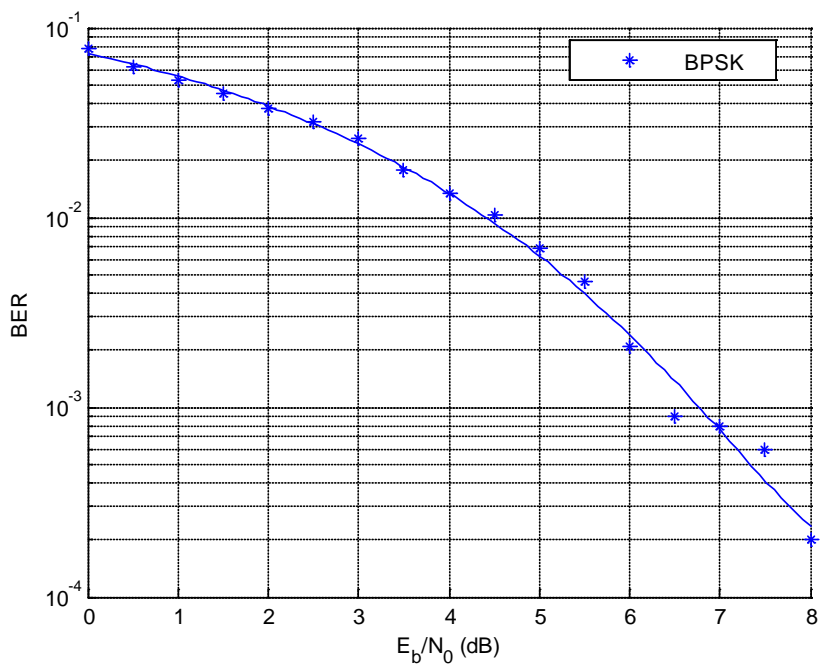

Figure 5: Bit Error Rate Performance for BPSK

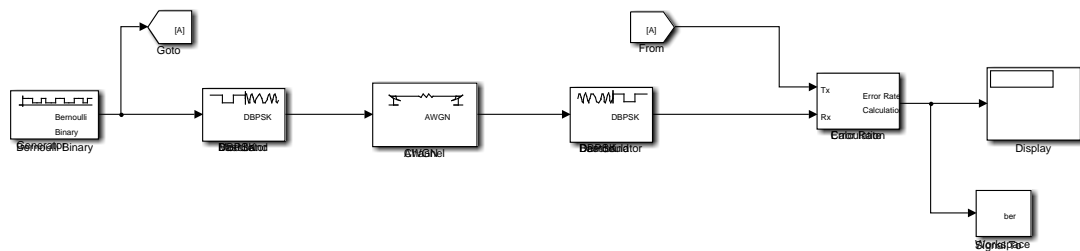

Figure 6: Simulink Model for DBPSK

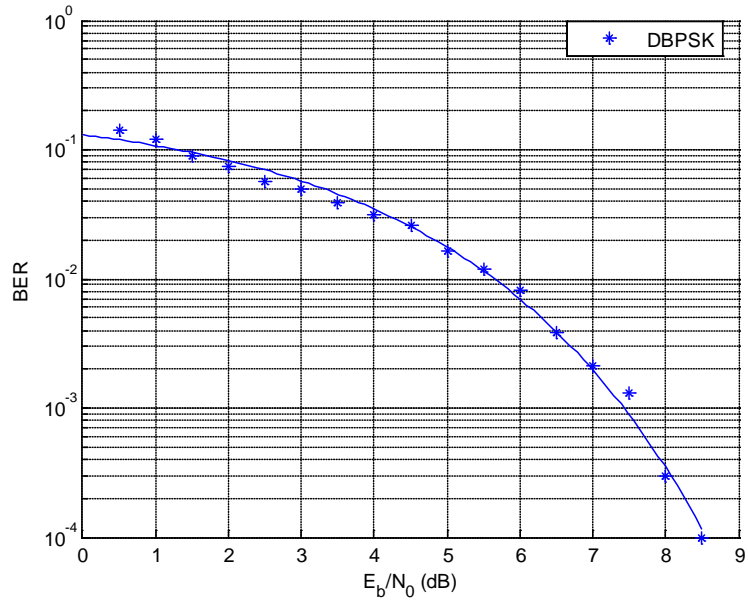

Figure 7: Bit Error Rate Performance for DBPSK

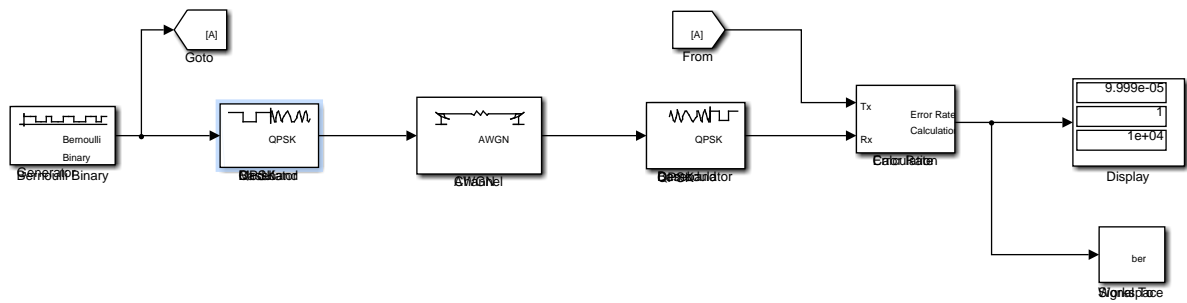

Figure 8: Simulink Model for QPSK

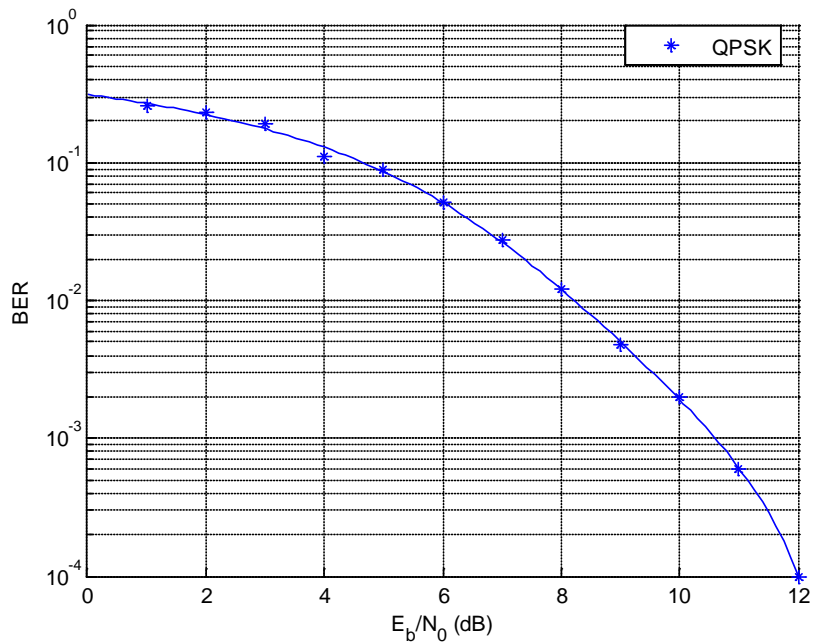

Figure 9: Bit Error Rate Performance for QPSK

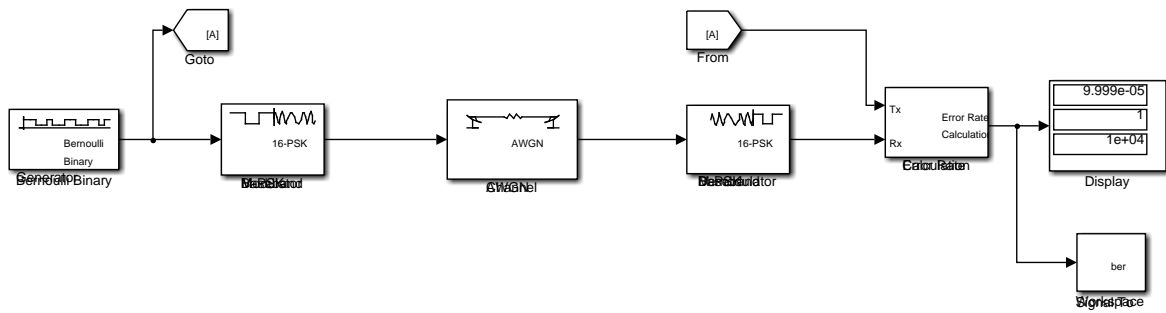

Figure 10: Simulink Model for M-ary PSK

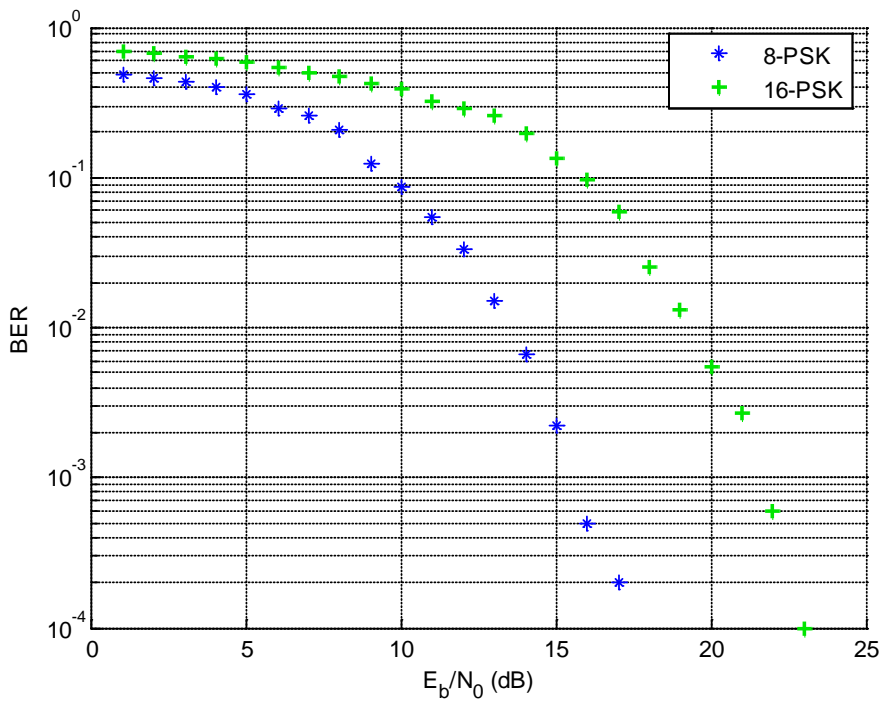

Figure 11: Bit Error Rate Performance for M-ary PSK

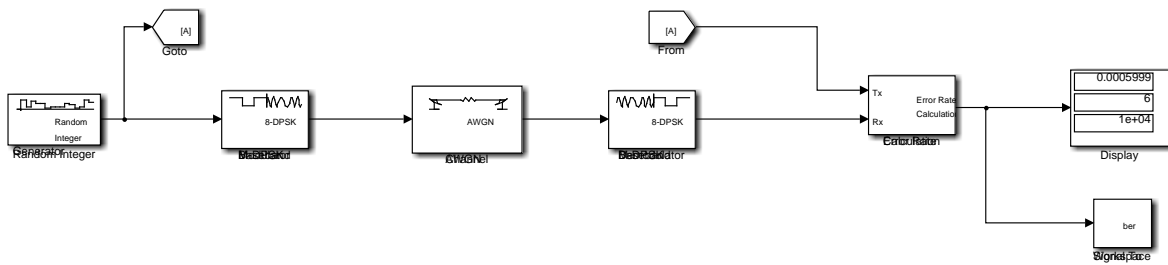

Figure 12: Simulink Model for M-ary DPSK

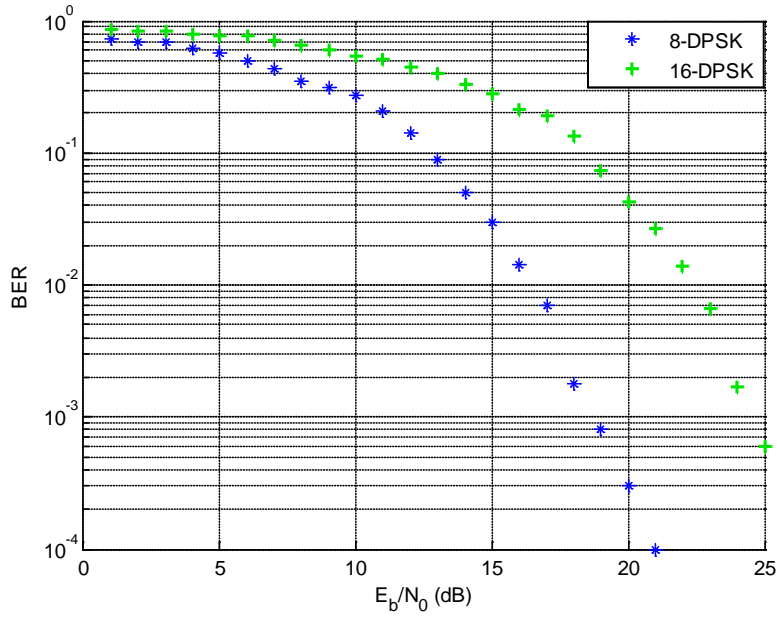

Figure 13: Bit Error Rate Performance for M-ary DPSK

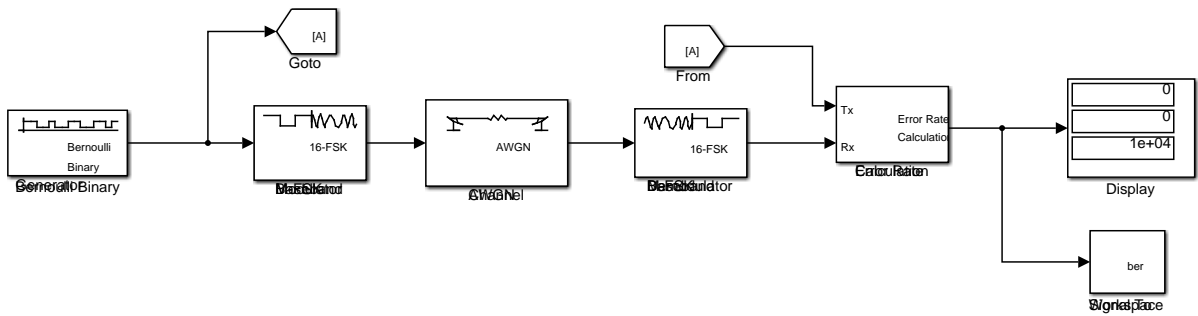

Figure 14: Simulink Model for M-ary FSK

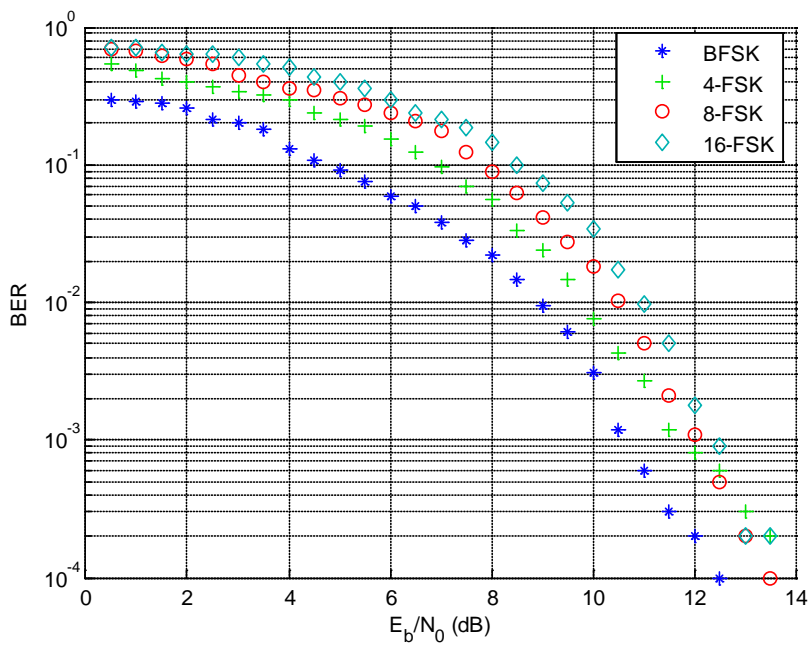

Figure 15: Bit Error Rate Performance for M-ary FSK

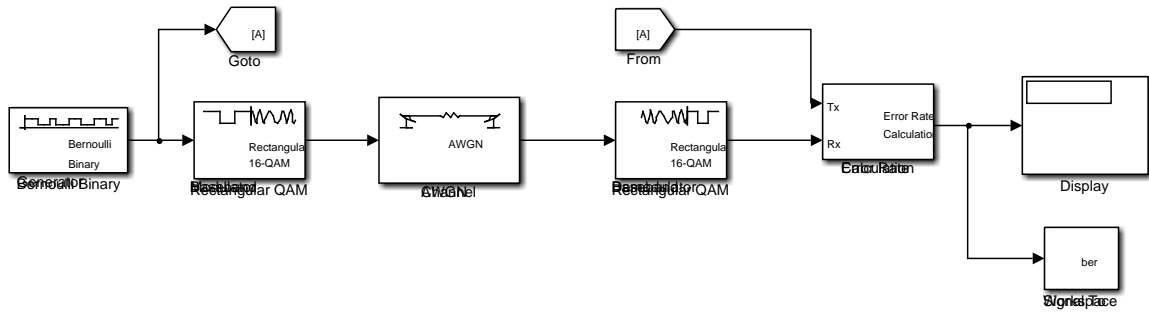

Figure 16: Simulink Model for QAM

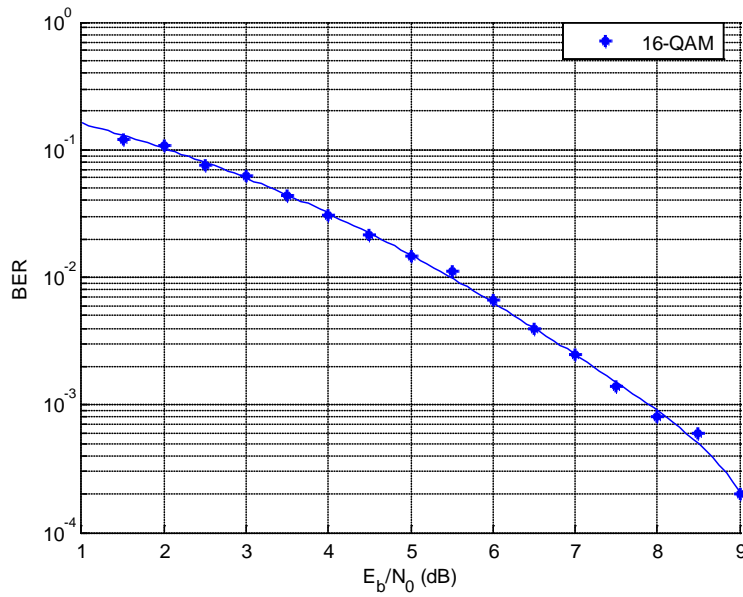

Figure 17: Bit Error Rate Performance for 16-QAM

Table 1: Bit Error Rate for 100000 bits transmission.

E_b/N_0	BPSK	DBPSK	QPSK	16-QAM
1	0.05663	0.14090	0.24230	0.13680
2	0.03834	0.10130	0.19630	0.09231
3	0.02345	0.06752	0.15030	0.05654
4	0.01279	0.04123	0.10940	0.03045
5	0.00626	0.02156	0.07373	0.01439
6	0.00236	0.00914	0.04519	0.00564
7	0.00072	0.00341	0.02433	0.00183
8	0.00024	0.00096	0.01149	0.00057

6. Result and Discussion

Bit Error rate Curve for BPSK, DBPSK, QPSK, M-PSK, M-DPSK, M-FSK and QAM modulation using Simulink file is shown in Figures 5, 7, 9, 11,13, 15 and 17. For M- ary PSK it is seen from Figure 11 that if the value of M increases for 8 to 16 the value of bit error rate also increases. As a result the performance of the system decreased. We can say the 8-ary PSK is better than 16-ary PSK. From Figure 13 it is seen that 8-DPSK has better performance than 16-DPSK. It is also clear from Figure 15 that BFSK has better performance than other higher order FSK. Comparing Figures 11, 13 and 15 it can be said that for M-ary modulation, if the value of M increases the performance of the system will be degrade. Form table -1 we see that BPSK Modulation has better performance than DBPSK, QPSK and 16-QAM

7. Conclusion

In this paper; three basic types of modulation was discussed. A number of modulation schemes such as BPSK, QPSK, BFSK, DBPSK, M-PSK, M-FSK and QAM have been consider for MATLAB simulation purposes. Their BER have been evaluated using MATLAB Monte Carlo simulation tool for additive white Gaussian noise channel. We have concluded from the above figures depending on bit error rate that BPSK is the most effective modulation schemes in a practical communication system.

References

- [1] R. F. PAWULA, "On Mary DPSK Transmission Over Terrestrial and Satellite Channels", IEEE transactions on communications, vol. Com-32, no. 7, july 1984
- [2] Bernard Sklar, "Raleigh fading channel in mobile communication system part I: characterization", IEEE Communications Magazine Volume 35 issue 7 1997.
- [3] Fuqin Xiong, "Digital Modulation Techniques", Second Edition, Artech House, 2006.
- [4] Anurag Sharma and Anita Garhwal, "Performance analysis of physical layer of wimax system using Simulink" Anurag Sharma, et al International Journal of Computer and Electronics Research, Volume 2, Issue 2, April 2013.
- [5] Navjot Kaur and Lavish Kansal, "Performance Comparison of MIMO Systems over AWGN and Rician Channels with Zero Forcing Receivers", International Journal of Wireless & Mobile Networks (IJWMN) Vol. 5, No. 1, February 2013
- [6] Pankaj Anand, Akhil Gupta and Sonam Bhagat, "Bit Error Rate Assessment of Digital Modulation Schemes on Additive White Gaussian Noise, Line of Sight and Non Line of Sight Fading Channels", International Journal of Engineering Science Invention, Volume 3 Issue 8, September. 2014
- [7] Marvin K. Simon and Mohamed-Slim Alouini. "Digital Communication over Fading Channels", John Wiley & Sons, Inc
- [8] Manoj Barnela, "Digital Modulation Schemes Employed in Wireless Communication: A Literature review" International Journal of Wired and Wireless Communications Vol.2, Issue 2, April, 2014
- [9] John G. Proakis and Masoud Salehi, "communication systems engineering", 2nd Ed, prentice hall, 2001
- [10] Vinay Panwar and Sanjeet Kumar. "Bit Error Rate (BER) Analysis of Rayleigh Fading Channels in

- Mobile Communication”, *International Journal of Modern Engineering Research (IJMER)* Vol.2, Issue.3, May-June 2012 pp-796-798
- [11] T. S. Rappaport. “Wireless Communications: Principles and Practice”, Upper Saddle River, NJ: Prentice Hall, 1996.
- [12] H. J. Richter, A. Y. Dobin, O. Heinonen, K. Z. Gao, R. Veerdonk, R. T. Lynch, J. Xue, D. Weller, P. Asselin, M. F. Erden, and R. M. Brockie, "Recording on bit-patterned media at densities of 1 Tb/in² and beyond", *IEEE Transactions on Magnetics*, vol. 42, pp. 2255-60, 2006.
- [13] B. Livshitz, A. Inomata, H. N. Bertram, and V. Lomakin, "Analysis of recording in bit patterned media (BPM) with parameter distributions," *Journal of Applied Physics*, vol. 105, pp. 07C111, 2009.
- [14] V. Chauhan, M. Arora and R.S. Chauhan, Comparative BER Performance of PSK based Modulation Techniques under Multipath Fading , *Advances in Applied Science Research* , 2011, 2(4): 521 -524.