

# Characterization of *Oreochromis niloticus* Strains of Lake Kariba Culture Fisheries using Morphological and Meristic Methods

Mauris Chinyama Makeche<sup>a\*</sup>, Walter Muleya<sup>b</sup>, Tamuka Nhiwatiwa<sup>c</sup>

<sup>a,c</sup>Department of Biological Sciences, Faculty of Science, University of Zimbabwe, P. O. Box MP 67, Harare, Zimbabwe

<sup>a,c</sup>University of Zimbabwe Lake Kariba Research Station, P.O. Box 7, Kariba, Zimbabwe

<sup>b</sup>Department of Biomedical Sciences, School of Veterinary Medicine, University of Zambia, P. O. Box 32379

<sup>a</sup>Email: [maurismakeche@yahoo.com](mailto:maurismakeche@yahoo.com)

<sup>c</sup>Email: [drtnhiwatiwa@gmail.com](mailto:drtnhiwatiwa@gmail.com)

## Abstract

*Oreochromis niloticus* fish collected from Yalelo Fishery, Fwanyanga Fishery and Choombwe Fishery of Lake Kariba were investigated by multivariate analysis of 23 morphometric measurements and 7 meristic counts. Dendrograms were used to delineate the sampled specimens using PC-ORD™ Software and the differences among strains were tested using One-way ANOVA in Statistix 9 Software ( $P = 0.05$ ). Meristic analysis did not show a high divergence among the strains while morphometric analysis showed that the sampled fish could be characterized into three different strains. These results showed that the tested fish samples could be grouped into 3 types based on morphometric characters. The morphometric differences among the sampled *O. niloticus* strains may have appeared due to genetic differences among the collected specimens.

**Keywords:** Dendrogram; Yalelo Fishery; Fwanyanga Fishery; Choombwe fishery.

---

\* Corresponding author.

## 1. Introduction

The Nile *Tilapia*, *Oreochromis niloticus* (Linnaeus, 1758), is a widespread species used in tropical Aquaculture. Natural populations of these fish occur in Africa and the species *O. niloticus* has been introduced to almost every tropical country in the world for Aquaculture purposes [1]. The Fisheries sub-sector in Zambia contributes approximately 3.2% to the National Gross Domestic Product (GDP). The Aquaculture sub-sector currently contributes 27% of the total fish produced in Zambia. The sector has experienced some increase in production from 12, 998 metric tonnes in 2012 to 32, 888 metric tonnes in 2017. Aquaculture production is expected to increase by 1, 148 metric tonnes by December, 2020 due to the various interventions by the Zambian Government [2]. The increase in fish production is attributed to the commercialization of the Fisheries sub-sector which has witnessed an increase in the number of people venturing into fish farming. Besides the economic returns from *Tilapia* Aquaculture, tilapiines have also been adopted for use as control-agents for aquatic vegetation and elimination of unwanted aquatic fauna such as snails and mosquitoes [3]. *Oreochromis niloticus* is the most widely cultured bream in Zambia and its success in Lake Kariba Culture Fisheries is because it is extremely hardy, it has a wide range of trophic and ecological adaptations, and it possesses adaptive life history characteristics such as fast growth, high fecundity, big egg sizes that have few predators, high dietary overlap across size, class, habitat and season [4,5,6]. ‘Characterization’ refers to the description of a character or quality of an individual or entity [7]. The word ‘characterize’ is synonymous to the word ‘distinguish’, that is, to mark as separate or different, to individualize, to differentiate, or to separate into kinds, classes or categories. This identification may in broad terms refer to any difference in the appearance or make-up of an accession. The term ‘characterization’ refers to the description of characters that are usually highly heritable, easily seen by the eye and equally expressed in all environments [8]. Morphometric and the meristic methods remains the simplest and most direct way among methods of species identification. From previous studies [9,10,11,12] it is understood that the analysis of phenotypic variation in morphometric measurements or meristic counts is the method most commonly used to delineate stocks of fish. Despite the advent of techniques which directly examines biochemical or molecular genetic variation, these conventional methods continue to have an important role in stock identification even to date [3]. The general objective of the study was to characterize *Oreochromis niloticus* strains of Lake Kariba Culture Fisheries using morphological and meristic methods. The study used simple and cheap methods to establish whether or not the *O. niloticus* fish species being reared by fish farmers of Lake Kariba are the same or not. It is important to characterize the cultured fish species in order to re-strategize management practices. It is hoped that the results of this study will form the basis of taxonomic description of *O. niloticus* strains of Lake Kariba Culture Fisheries. The research was limited to Lake Kariba because it houses Zambia’s largest Commercial Fishery called Yalelo Fishery Limited, and it is the largest man-made Lake in Zambia that has diverse ecological habitats that are rich in fish biodiversity.

## 2. Materials and Methods

The study was conducted from Lake Kariba (Figure 1) which lies between latitude 16°28’S and 18°06’ S, and longitude 26°40’E to 29°03’ E. Lake Kariba has a catchment area of 663,000km<sup>2</sup> with a maximum length and maximum width of 280km and 40km. Lake Kariba has a total surface area of 5,580km<sup>2</sup>. Lake Kariba has a water storage capacity of 185 km<sup>3</sup>, making it the largest man-made lake in Southern Africa [13]. Fish samples

were collected from cage Aquaculture fish farms of Lake Kariba. Fish samples were collected in April and May, 2020 from Yalelo Fishery Limited, Fwanyanga Fishery and Choombwe Fishery. Yalelo Fishery Limited is a commercial Fishery which is located in Kamimbi bay along longitude 28.63° E and latitude -16.47° S. 66 fish samples were collected from Yalelo Fishery Limited. Fwanyanga Fishery is a subsistence Fishery located in Kabyobybo bay along longitude 28.68° E and latitude -16.52° S. 81 fish samples were collected from Fwanyanga Fishery. Choombwe Fishery is a subsistence Fishery that lies along longitude 28.02° E and latitude -16.00° S. 64 fish samples were collected from Choombwe Fishery.

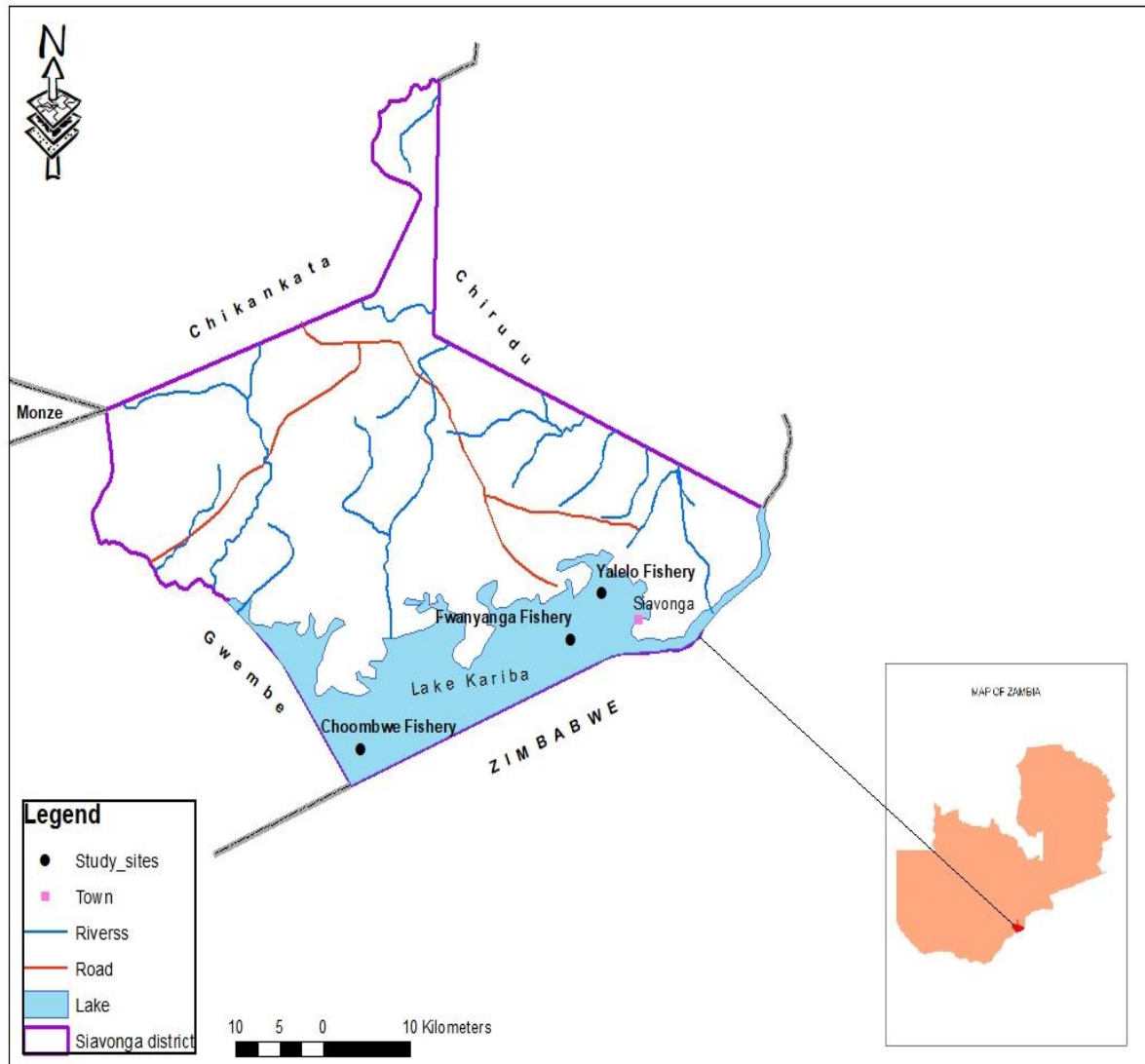

**Figure 1:** Location of the study sites within Lake Kariba

The sampled data was combined because the fingerlings from all the sampled Fisheries were from the same brood stock housed at Chirundu Breeds. A total of 30 morphological characters were used which included 23 morphometric measurements and 7 meristic counts. Meristic counts included number of dorsal fin spines (DFS), number of dorsal fin rays (DFR), number of anal fin spines (AFS), number of anal fin rays (AFR), number of lateral line scales (LLS), number of scales from the lateral line to the dorsal fin (LLD) and number of scales

from the lateral line to the ventral fin (LLV). Morphometric measurements were measured to the nearest 0.1cm except for body weight (BW) which was measured to the nearest 0.1g using an SF-400A electronic compact scale. Other morphometric measurements included (Figure 2) total length (TL), standard length (SL), head depth (HD), body height (BH), head length (HL), pre-dorsal distance (PDD), pre-anal distance (PAD), pre-pectoral distance (PPD), pre-ventral distance (PVD), pectoral fin length (PFL), ventral fin length (VFL), dorsal fin base length (DFBL), anal fin length (AFL), inter-orbital distance (IOD), eye diameter (ED), snout length (SNL), caudal peduncle length (CPL), Caudal peduncle depth (CPD), greatest dorsal spine length (GDSSL), third anal spine length (TASL), longest anal ray length (LARL) and post-orbital length (POL).

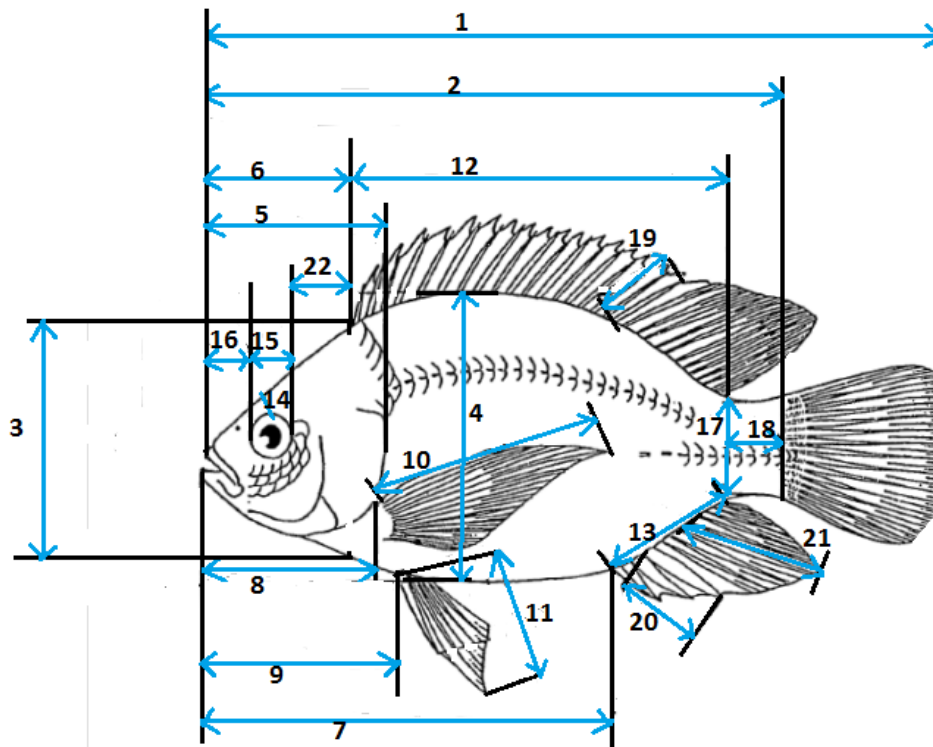

**Figure 2:** Diagram of morphometric measurements (Adopted from [14]).

Since meristic characters are independent of size of the fish and do not change during growth [11,15] the raw meristic data were used in the analysis. However, to avoid possible biases produced by size effects on the morphometric variables, all morphometric characters were standardized in PC-CORD™ Software version 5.10 [16] before constructing dendrograms. Meristic and morphometric dendrograms were constructed in order to identify the number of *O. niloticus* strains among the sampled fish at 50% similarity index in PC-CORD™ Software version 5.10. Meristic data was used to construct the dorsal formula and anal formula of the sampled fish. Analysis was carried out separately for morphometric and meristic characters. This is because the two types of variables are different with respect to statistical (morphometric are continuous and meristic are discrete) and biological data (morphometric characters can be susceptible to environmental factors while most meristic characters are fixed early during the development) [11]. Statistix Software version 9.0 [17] was used to determine significant differences ( $P = 0.05$ ), if any, among the meristic and morphometric variates of

*Oreochromis niloticus* strains.

IBM Statistics Software version 21.0 [18] was used to determine the number of principal components in multivariate analysis among the determined *O. niloticus* strains of Lake Kariba Culture Fisheries.

### 3. Results

#### 3.1. Meristic results

The dendrogram that was constructed to characterize the collected *Oreochromis* fish samples of Lake Kariba Culture Fisheries based on meristic counts is given in Figure 3.

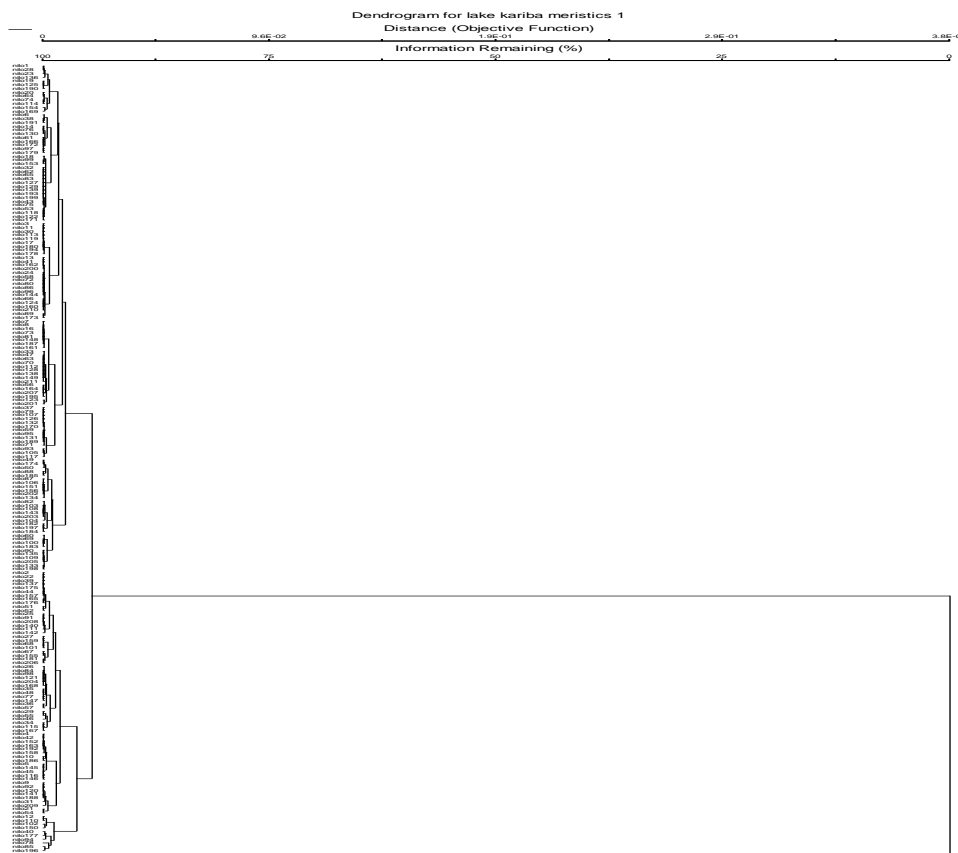

**Figure 3:** Dendrogram of meristic counts of sampled fish from Lake Kariba Culture Fisheries.

The dendrogram showed that the sampled fish specimens of Lake Kariba Culture Fisheries can be characterized into two strains (types) at 50% similarity index, namely strain 1 and strain 2. Strain 1 contained *Oreochromis niloticus* number 18 while strain 2 contained all the other *Oreochromis niloticus* samples of Lake Kariba. The identified strains were discriminated on 3 principal components. The eigen values ranged from a low of 1.003 for principal component 3 to a high of 1.254 for principal component 1. Principal component 2 had an eigen value of 1.141. The extracted principal component accounted for a cumulative percent variance of 48.534%. The contribution of each meristic variate to the observed variation in each of the 3 principal components is given in Table 1.

**Table 1:** Principal component loadings for meristic counts of Lake Kariba Culture Fisheries

	Component		
	1	2	3
DFS	.462	.037	.483
DFR	-.662	.255	.185
AFS	-.187	.217	.696
AFR	-.180	-.414	.397
LLS	.550	.399	.231
LLD	.454	-.473	.015
LLV	.165	.688	-.199

The most influential meristic counts in principal component 1 which caused the largest variation and were important in strain identification were LLS, DFS, LLD and LLV. From the raw meristic counts, it was determined that the dorsal formula of *Oreochromis niloticus* strains of Lake Kariba Culture Fisheries can be expressed as: D XVI-XVIII, 11-13 while the anal formula of *Oreochromis niloticus* strains of Lake Kariba Culture Fisheries can be expressed as: A III-IV, 9-11.

**3.2. Morphometric results**

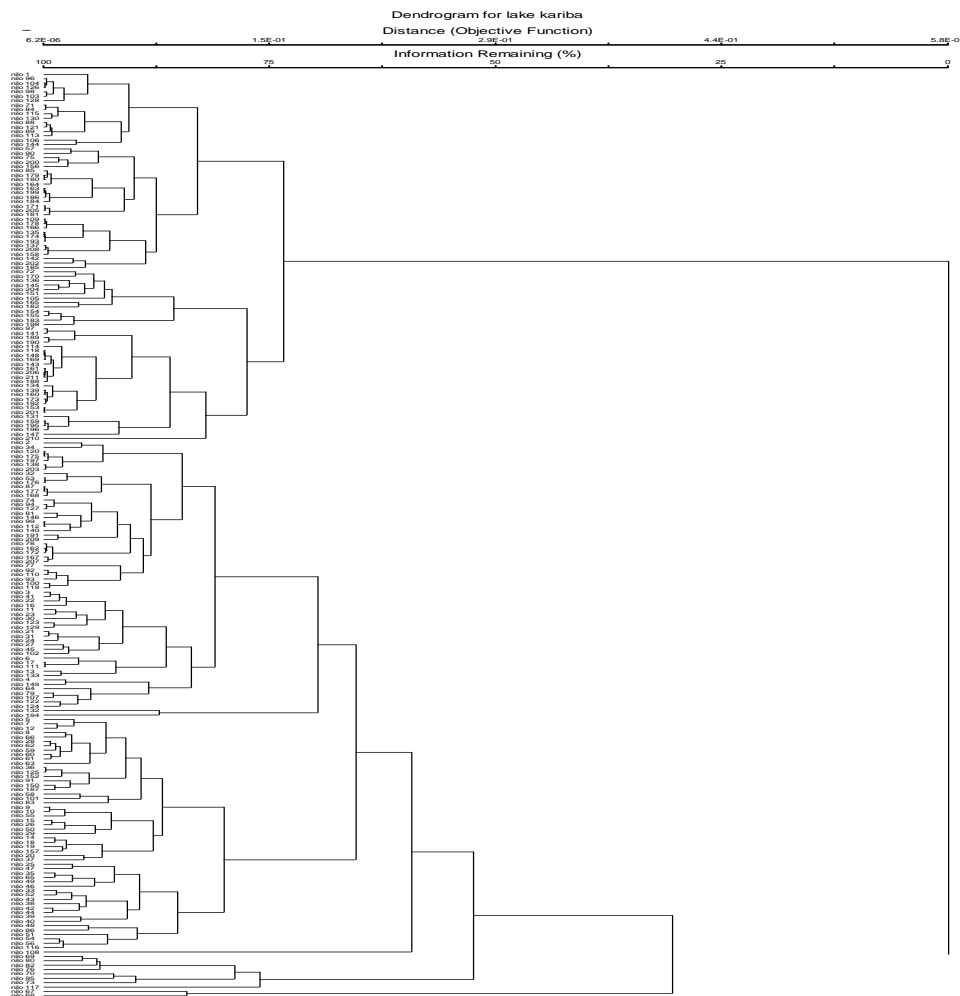

**Figure 4:** Dendrogram of morphometric measurements of sampled fish from Lake Kariba Culture Fisheries

The dendrogram that was constructed to characterize the collected *Oreochromis* fish samples of Lake Kariba Culture Fisheries based on morphometric measurements is given in Figure 4.

The dendrogram showed that the sampled fish specimens of Lake Kariba Culture Fisheries can be characterized into three strains (types) at 50% similarity index. One-way Analysis of Variance conducted in Statistix Software version 9.0 [17] on the morphometric variates of the identified strains in order to determine significant differences ( $P = 0.05$ ), if any, showed that there was a significant difference ( $P = 0.0000$ ) among the morphometric variates of Lake Kariba Culture Fisheries. The Least Significant Difference (LSD) All-Pairwise Comparison Test was then used to determine which means were statistically different ( $P = 0.05$ ) from the other. The results of the LSD test conducted in Statistix Software version 9.0 [17] are given in Table 2.

**Table 2:** LSD All-Pairwise Comparison Test results of morphometric variates of Lake Kariba Culture Fisheries

Variable	Mean	Homogenous groups
Strain 1	96.850	A
Strain 2	69.676	B
Strain 3	56.72	C

The results of the LSD All-Pairwise Comparison Test showed that there were three different types of *Oreochromis niloticus* strains at Lake Kariba. The three different types of *Oreochromis niloticus* strains were assigned to three different homogenous groups namely A, B and C with different mean morphometric variates. The identified strains were discriminated on 4 principal components. The smallest principal component was observed in principal component 4 which had an eigen value of 1.317 and the largest eigen value was observed in principal component 1 with an eigen value of 10.623. Principal components 2 and 3 had the eigen values 2.148 and 1.731. the extracted principal components accounted for a cumulative percent variance of 68.778%. The most influential morphometric measurement in principal component 1 which caused the largest variation and were important in strain identification were TL, BW, SL, BH, HL, PAD and PVD. The communalities test that was performed in IBM Statistics Software version 21.0 [18] to determine the most important morphometric variable in the description of the identified *O. niloticus* strains of Lake Kariba Culture Fisheries showed that total length with an extraction coefficient of 0.948 was the most important variable while pre-dorsal distance with an extraction coefficient of 0.264 was the least important.

#### 4. Discussion

The general sentiment shared by Fisheries managers regarding Lake Kariba Culture Fisheries is that there are many different strains of *Oreochromis niloticus* being farmed by Aquaculture farmers [19]. Morphometric results of this study showed that there are 3 strains of *Oreochromis niloticus* being farmed within Lake Kariba. These morphometric results are in agreement with other studies by [12] who morphometrically identified two species of *Oreochromis niloticus* at Lake Barigo. [10,14] also identified two species of *Oreochromis niloticus* using morphometric analyses. [11] also delineated *Tilapia* samples from Reservoirs in Sri Lanka into four groups using morphological methods. The results of the study agree with [20] hypothesis that most fish farmers

keep more than one *Tilapia* strain and there is a possibility of the presence of inter-strain hybrids within a Culture Fishery. Morphometrically, the characters measured in all principal components except 1 had mixed coefficients indicative of shape variations rather than variation in size. This observation is in harmony with findings by [12,15] who observed that, any component having all coefficients of the same sign was indicative of size variation whereas any component having both positive and negative coefficients was indicative of shape variation. This observation implies that *Oreochromis niloticus* strains being farmed by Aquaculture farmers of Lake Kariba differ in shape. This, too, is a popular opinion shared by Fisheries managers in Zambia [19]. Meristic results of this study showed that there are 2 strains of *Oreochromis niloticus* being farmed by Aquaculture farmers of Lake Kariba. Meristic and morphometric results thus complemented each other. The dorsal formula of *Oreochromis niloticus* strains of Lake Kariba Culture Fisheries was found to be D XVI-XVIII, 11-13 and the anal formula of *Oreochromis niloticus* strains of Lake Kariba Culture Fisheries was A III-IV, 9-11. These results are within the range of results that were found from previous studies by [9,12,21]. Previous studies on *Oreochromis* fish species indicated that the number of anal spines always ranges between III to IV while the number of dorsal spines varies between XV to XVIII [9,12,21]. This study could not phenotypically delineate *Oreochromis niloticus* strains at high similarity index (95%) to sub-species level because of overlapping meristic counts from the sampled specimens. This finding is agreeable with the hypothesis by [11,12,21] which stated that meristic counts do not show sufficient divergence among *Tilapia* populations. All *Oreochromis niloticus* strains show overlapping narrow-ranged meristic counts and any divergence of characters from a standard range could be fatal to the individual because it can be indicative of a mutation [14]. This could be the reason why closely-related species or sub-species have a narrow variable range of meristic counts. The high similarity among meristic traits signifies a possibility of hybridization among *O. niloticus* strains of Lake Kariba Culture Fisheries. All the sampled Fisheries on Lake Kariba had fish samples with the same dorsal formula and anal formula because the brood stock is purchased from Thailand by Chirundu Breeds in Chirundu, Zambia where all fish farmers from Lake Kariba buy fingerlings from. Any variation in the number of strains at each Fishery can be attributed to differences in levels of hybridization at each Fishery. The presence of three strains of *Oreochromis niloticus* within Lake Kariba Culture Fisheries may suggest that fish farmers of Lake Kariba are possibly farming the three commonly cultured *Oreochromis niloticus* strains, namely: Genetically Improved Farmed *Tilapia* (GIFT), *Oreochromis niloticus* Chitralada and *Oreochromis niloticus niloticus* [20,22].

## 5. Conclusion

This study used morphometric and meristic methods to establish the existence of more than one type of *Oreochromis niloticus* fish species among Lake Kariba Culture Fisheries. This study provided Aquaculture farmers, researchers and Fisheries workers a useful tool for the identification and assessment of stock status of *O. niloticus* strains. Since the identification of fish populations and their connectivity with each other is a major point for management, breeding and conservation of species, the use of morphometric and meristic traits in delineating fish species is very effective.



## 6. Recommendations

Phenotypically, this study delineated *Oreochromis niloticus* fish species of Lake Kariba Culture Fisheries using meristic counts and morphometric measurements. Similar studies should be conducted in other Aquaculture Fisheries to ascertain the number of *O. niloticus* strains being reared in Zambia. Application of molecular genetic markers such as microsatellites, cytochrome c oxidase subunit 1 (CO 1) gene and the displacement loop (D-loop) region would be effective methods of examining the discreteness of *O. niloticus* strains of Lake Kariba Culture Fisheries and facilitate the development of species-specific management strategies.

## Acknowledgements

This study was part of the Ph. D study of the first author, funded by the African Development Bank through the Zambia Aquaculture Enterprise Development Project and the Ministry of Fisheries and Livestock of Zambia. I would like to thank my supervisors Prof. Tamuka Nhiwatiwa (University of Zimbabwe) and Dr. Walter Muleya (University of Zambia) for guiding my thoughts in writing this article. I also thank Mr. Walubita Nasilele (Fisheries Aquaculture Officer, Siavonga, Zambia) for accompanying me in the field during data collection.

## 7. Copyright declaration

We, the authors, do hereby declare that this Journal article represents our own work and that it has not previously been submitted for publication to this or another Journal.

## References

- [1]. E. N. Nchimunya, J. Kaunda and C. J. Nkunde. (2018, June 3). The Aquaculture sub-sector in Zambia: challenges and opportunities. (2<sup>nd</sup> edition). [On-line]. 3(2). [www.pmrzambia.com](http://www.pmrzambia.com) [December 13, 2019].
- [2]. S. Mvula and P. Mwila. "State nods 700 Aquaculture loans." Zambia Daily Mail. (April 15, 2020), Volume 12, issue 103. Pp.1-3.
- [3]. J. S. Bradbeer, H. Jack, H. W. Watson, A. Shechonge, R. Tamatamah, B. P. Ngatunga, F. G. Turner and M. J. Genner. (2018, May 5). Limited hybridization between introduced and critically endangered indigenous tilapia fishes in northern Tanzania. (3<sup>rd</sup> edition). [On-line]. 4(2) <http://doi.org/10.1007/s/10750-018-3572-5>. [Dec. 14, 2018].
- [4]. D. W. Nyingi, L. De Vos, R. Aman and J. F. Agnese. "Genetic characterization of an unknown and endangered native population of the Nile Tilapia *Oreochromis niloticus* (Linnaeus, 1758) (Cichlidae) in the Loboï Swamp (Kenya)." Aquaculture, Vol. 297 (2), pp. 57-63, Jan. 2009.
- [5]. T. A. Zengeya, A. J. Booth, A. D.S. Bastos and C. T. Chimimba. "Trophic interrelationships between the exotic Nile Tilapia, *Oreochromis niloticus* and indigenous tilapiine cichlids in a subtropical African river system (Limpopo River, South Africa)." Environmental Biology of Fishes, Vol. 92 (3), pp. 479–489, March, 2012.
- [6]. M. Nyirenda. "Abundance, Growth and Reproductive biology of Nile Tilapia, *Oreochromis niloticus* (Linnaeus, 1758) on Lake Kariba in comparison with tilapiines indigenous to the Middle Zambezi."

- M.Sc. dissertation, University of Zambia, Zambia, 2017.
- [7]. K. Merriam-Webster. Webster's ninth new collegiate dictionary. Massachusetts: Merriam-Webster Incorporation, 1991, pp. 425.
- [8]. M. Siankunku. "Characterization of selected Zambian rice (*Oryza sativa*) accessions using simple sequence repeat markers." M.Sc. dissertation, University of Zambia, Zambia, 2016.
- [9]. C. Katongo. "The Evolutionary Biology and Taxonomic Review of Zambian Riverine Haplochromine Cichlids." Ph.D. thesis, University of Zambia, Zambia, 2005.
- [10]. A. Yakubu and S. A. Okunsebor. "Morphometric Differentiation of Two Nigerian Fish Species (*Oreochromis niloticus* and *Lates niloticus*) Using Principal Components and Discriminant Analysis." International Journal of Morphology, Vol. 29 (4), pp. 1429-1434, April, 2011.
- [11]. S. P. Samaradivakara, O. E. Sala, F.S. Chapin, J. J. Armesto, E. Berlow, J. Bloomfield, R. Dirzo, E. Huber-Sanwald, N. Y. Hirimuthugoda, R. H. A. N. M. Gunawardana, R. J. Llleperuma, N. D. Fernandopulle, A. D. De Silva and P. A. B. D. Alexander. "Morphological Variation of Four Tilapia Populations in Selected Reservoirs in Sri Lanka." Tropical Agricultural Research, Vol. 23 (2), pp. 105-116, May, 2012.
- [12]. Y. Chuhila. "Assessment of changes in genetic diversity of Nile Tilapia, *Oreochromis niloticus* (Linnaeus, 1758), of Lake Baringo, Kenya." M.Sc. dissertation, University of Nairobi, Kenya, 2015.
- [13]. C. Mudenda, H. G. Mudenda and A. Banda. (June 28, 2012). "Environmental Impact Assessment Report on the development of a Tilapia Aquaculture Project in Kamimbi, Siavonga District on Lake Kariba." Yalelo Fisheries Limited. [On-line]. <http://www.fao.org/fishery/code/en>. [May 19, 2020].
- [14]. E. J. Vreven, B. Adepo-gourene, J. F. Agnese and G. G. Teugels. "Morphometric and Allozyme variation in natural populations and cultured strains of the Nile Tilapia *Oreochromis niloticus* (Teleostei-Cichlidae)." Belgian Journal of Zoology, Vol. 128 (2), pp. 23-34, November, 1998.
- [15]. J. Lleonart, J. Salat and C. J. Torres. "Removing allometric effects of body size in morphometric analysis." Journal of Biology, Vol. 205 (6), pp. 85-93, January, 2000.
- [16]. B. McCune and M. J. Melford. "PC-ORD Software. Multivariate Analysis of Ecological Data." USA. Version 5.10, November 6, 2006.
- [17]. K. Bradley and B. Stanford. "Statistix Software". USA. Version 9.0. February, 2009.
- [18]. K. M. Stewart, B. Rhett and D. P. Snustad. "IBM SPSS Statistics Software." USA. Version 21.0. May, 2012.
- [19]. W. Nasilele. (2020, April 17). "Characterization of *Oreochromis niloticus* strains of Lake Kariba Culture Fisheries using morphological, meristic and genetic methods". Personal communication.
- [20]. A. B. Rafael, O-R. Raphael and A. B. Walter, A. B. (2016, June 16). "Identifying Nile Tilapia strains and their hybrids farmed in Brazil using microsatellite markers." Brasillia. [On-line]. 51(10), pp. 1744-1750. Available: <http://de.doi.org>. [June 8, 2019].
- [21]. P. H. Skelton. A complete guide to the freshwater fishes of Southern. South Africa: Southern Book Publishers, 2001, pp. 324-332.
- [22]. G. Anane-Taabeah, E. A. Frimpong and E. Hallerman. (2019, Oct 2). "Aquaculture-Mediated Invasion of the Genetically Improved Farmed Tilapia (Gift) into the Lower Volta Basin of Ghana.". Diversity. [On-line]. 11(188), pp. 1-22. Available: [www.mdpi.com/journal/diversity](http://www.mdpi.com/journal/diversity). [July 3, 2020].