

# Proposal of a Hybrid Structure Acoustic Wave Filter for Improving Quality of the Output Signal in the GSM 900 Band

Kalala Mutombo JM.<sup>a\*</sup>, Kafutshi Yav A.<sup>b</sup>, Selemani Kavuba D.<sup>c</sup>, Pandi Kiama C.<sup>d</sup>

<sup>a,c</sup>*Department of Electrical and Computer Engineering, Institut supérieur des techniques appliquées, Lubumbashi, D RC*

<sup>b,d</sup>*Department of Electromechanical Engineering, Institut supérieur des techniques appliquées, Lubumbashi, DRC*

## Abstract

This paper provides information on the study of acoustic bulk wave filter technologies, the Harmonic Bulk Acoustic Wave Resonator (HBAR) and the Bulk Acoustic Wave Resonator (FBAR) and proposes a hybrid structure (HBAR-FBAR). ) that would be a solution to overcome the disadvantage of HBAR technology manifested by an exaggerated occupation of harmonic frequencies around the resonant frequency when it used in the oscillators of mobile phone systems. The results show that hybrid technology is the best solution.

**Keywords:** Bulk Acoustic Wave (BAW); HBAR (Harmonic Bulk Acoustic Wave Resonator); FBAR (Film Bulk Acoustic Wave Resonator); MBVD (Butterworth Model Van-Dyke).

## 1. Introduction

Nowadays the technological growth is justified more in the communication radio with the mobile telephony. The transition from one generation to another generation influences the increase in data throughput for multiple services and requires the improvement of the quality service (QoS) over the radio interface (link between MS or UE and BTS or NodeB or eNodeB). The filters allow the standards in terms of frequency allocation to be well respected by the operators.

---

\* Corresponding author.

In the structure of a mobile telephony transmitter, the most exploited filtering technologies are those of acoustic surface wave (SAW) filters or those of acoustic bulk wave filters (BAW), but the BAW technologies ( Bulk Acoustic Wave) are gaining more market share on Surface Acoustic Wave (SAW) technologies because of their resonant frequency limit up to 2.5 GHz also due to the limitation of the interdigitated comb etching process (lithographic resolution) and their sensitivity to high levels of power above 1W. [1] BAW technologies become essential in mobile phone systems, because they intervene for any need to filter, select, eliminate echoes in the transmit (Uplink) and receive (DownLink) channel.

## 2. Materials and methods

### 2.1. materials

#### BAW filter manufacturing materials

In order to design high-frequency BAW structures, several industries have resolved to switch to using the chemical materials that will constitute the piezoelectric layer such as cadmium sulphide (CdS), zinc oxide (ZnO) and nitride. Aluminum (AlN) and for the substrate the use of silicon , (diamond, sapphire, Lithium Niobate LiNBO3) [2, 3, 4]

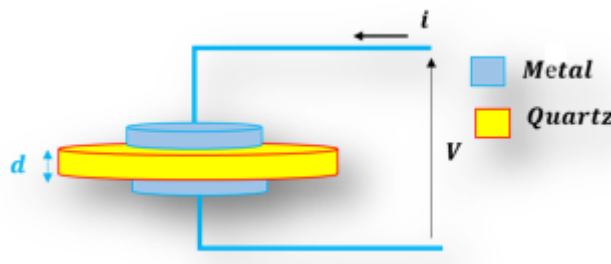

**Figure 1:** structure of BAW filter

BAW technologies take the configuration of piezoelectric materials and excitation of the volume acoustic wave whose propagation will be according to the thickness of the piezoelectric layer and at the different speed from that of the electromagnetic wave. The resonant frequency is independent of the width of the electrodes [3]. The excitation of the acoustic wave is materialized by an application of an electric field to the electrodes [5].

#### Frequency responses of BAW technology

The HBAR technology consists of the resonator (Metal-Piezoelectric-Metal) deposited directly on a low loss substrate and having a good surface state on its back face. The elementary resonator will behave as a transducer exciting a cavity in a harmonic mode hence the name of the resonator HBAR (Harmonic BAW Resonator).since the HBAR resonator operates in the harmonic mode, when selecting the resonance frequency, the harmonic frequencies that accompany the latter appear; the low effective piezoelectric coupling coefficient and low loss substrate incompatibility with CMOS technology means that the HBAR structure will be mainly used in oscillators or as a resonant part of an oscillator and not in duplexer filter applications. FBAR technology

consists of the elementary resonator, a membrane whose thickness is either equivalent to the piezoelectric layer or a little lower than the latter, and a substrate. The elementary resonator and its membrane are then suspended in the air by micromachining volume. The membrane part makes it possible to approach the behavior of the elementary resonator while minimizing the acoustic losses in the substrate. This technology has a better frequency selectivity compared to FBAR technology. The insufficiency of the FBAR structure returns to the insulation by an air cavity, which seems to penalize the level of heat dissipation towards the substrate, which

**2.2. Methods**

The goal of this work is to realize the FBAR and HBAR technologies from the RLC circuits based on the ButterWorth-Van Dyke (BVD) models and to propose their integration in an RF oscillator while cascading them. The cascading of these two technologies will allow us to be able to collect their performances to benefit from the best selectivity of the resonance frequency at the oscillator and a good temperature isolation of the oscillator before attacking an oscillator modulator [6]

**Approaching the BAW internal structure**

In view of the technologies presented, the internal structure of the BAW filtering technology takes the representation of a mini-capacitor of the armatures and a dielectric.

**ButterWorth Van Dyke Method (MBVD)**

According to Van Dyke, the elementary resonator is equivalent to an electrical circuit consisting of RLC dipoles. Since BAW filters operate in the acoustic mode, the  $R_x - L_x - C_x$  series branch is used to produce the acoustic mode. The capacitance  $C_{xo}$  coupled in parallel with this branch generate the resonance mode which subsequently sets the resonance frequency  $f_r$ . The resistance  $R_{xo}$  makes it possible to represent all the losses related to the substrate and to the piezoelectric layer [1, 6].

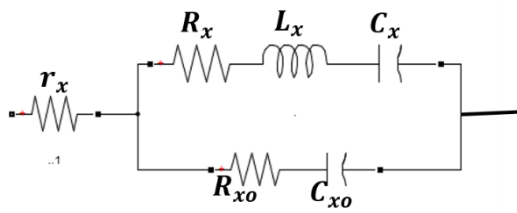

**Figure 2:** ButterWorth Van Dyke model

In figure 2, the resistance  $r_x$  introduces the losses at the electrodes of the BAW structure. This configuration completely fulfills the equivalence of the constitution and operation of the filter. From the realization point of view, the HBAR and FBAR filtering technologies can consist of the RCL dipoles, inspired by the ladder topology having a coupling of the resonators in series and in parallel. In practice, the realization of these technologies (HBAR, FBAR) is not so simple to do chemically but we use the Butter-Worth Van-Dyke

approach to clearly demonstrate and explain the performance of the hybridation [7].

### ButterWorth Van-Dyke model approach (MBVD) from HBAR

Resistor R1, which is in series with the series resonator, will have a small value to slightly introduce the losses of the electrodes, which will not have more harmful effects on the productivity of the resonance frequency [8, 9]. The series resonator in the series RLC branch, the resistor R3 will have a large value of a few kilo-ohm which would explain the introduction of losses related to the piezoelectric layer and the substrate as well as the presence of a spectral congestion around the resonant frequency  $f_r$  interpreting the harmonic mode of this technology. The resistance R2 will have a small value compared to the resistance R3 to not block the acoustic mode cycle. Finally, the capacitances C1 and C2 will have almost similar values for determining the resonant frequency. The parallel resonator remains the same as in the series resonator for assigning component values.

### FBAR ButterWorth Van-Dyke Model Approach (MBVD)

They are all identical by constitutions of the elements, then to obtain the different results between HBAR and FABR; it would be necessary to adapt the values of the resistances in the series resonator and in the parallel resonator. The use of FBAR filter shows a major interest to chase any spectral clutter as the case of HBAR and to have a selection of the frequency called on the spectrum [5].

### 3. Results and interpretations

Taking the first Bode diagram figure III from the result point of the HBAR technology, we find that before reaching the resonance frequency there is a leak of harmonics that accompany the working frequency and after this last there is also another part of leakage of harmonics; they are caused by the assignment of the large value of the  $5K\Omega$  (Kilo-Ohm) resistor in the series RC resonator and parallel resonator branch of the HBAR scheme.

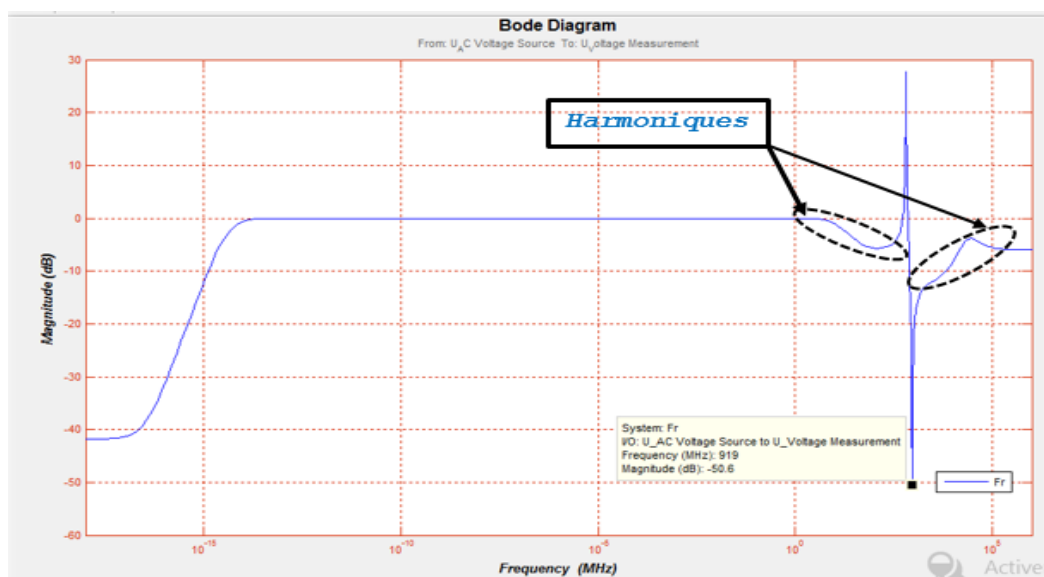
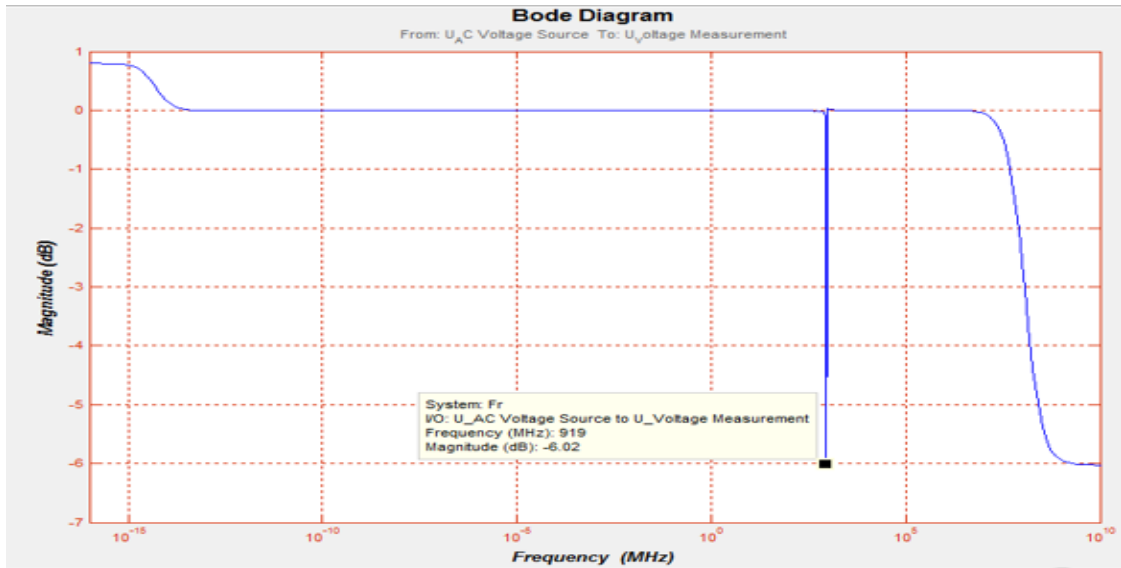

Figure 3: magnitude bode diagram for HBAR resonator

The black ellipsoids in broken lines on the Bode frequency versus amplitude diagram indicate the presence of the harmonics that interpret the exaggerated spectral occupancy around the frequency of the resonance frequency  $F_r = 919$  MHz.



**Figure 4:** magnitude Bode diagram for FBAR resonator

Secondly, when we look at the results in Figure 4 of the Bode diagram of the FBAR technology that mark a difference with the previous results of HBAR, there is an absence of harmonics around the resonant frequency and this effect is materialized by the assigning a small value of the resonator resistor 1 (Ohm) in the series resonator RC branch and parallel resonator. The resonance frequency  $F_r = 919$  MHz with FBAR is found perfectly. The hybrid cascade structure was realized under Matlab / simulink. We considered at the input a HBAR resonator and at the output a FBAR resonator. It is clearly visible on the Bode diagram of the figure 6 that the neighboring frequencies undergo a strong attenuation and the noises are more attenuated. The structure could better solve the problem of signal quality [2].

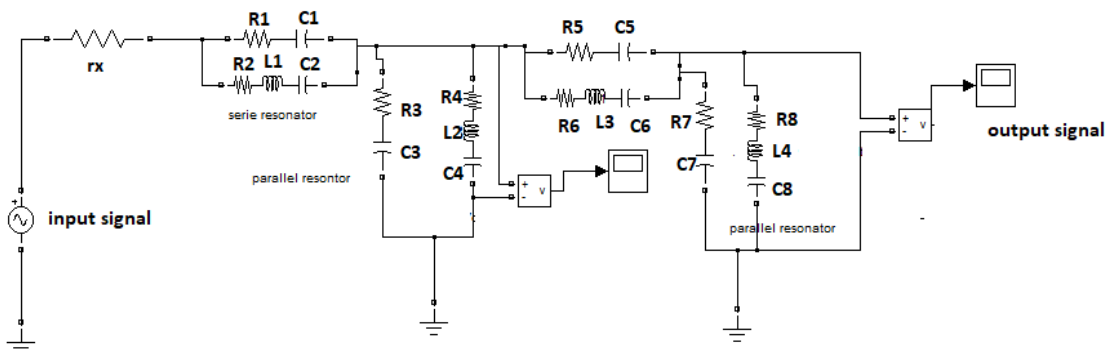
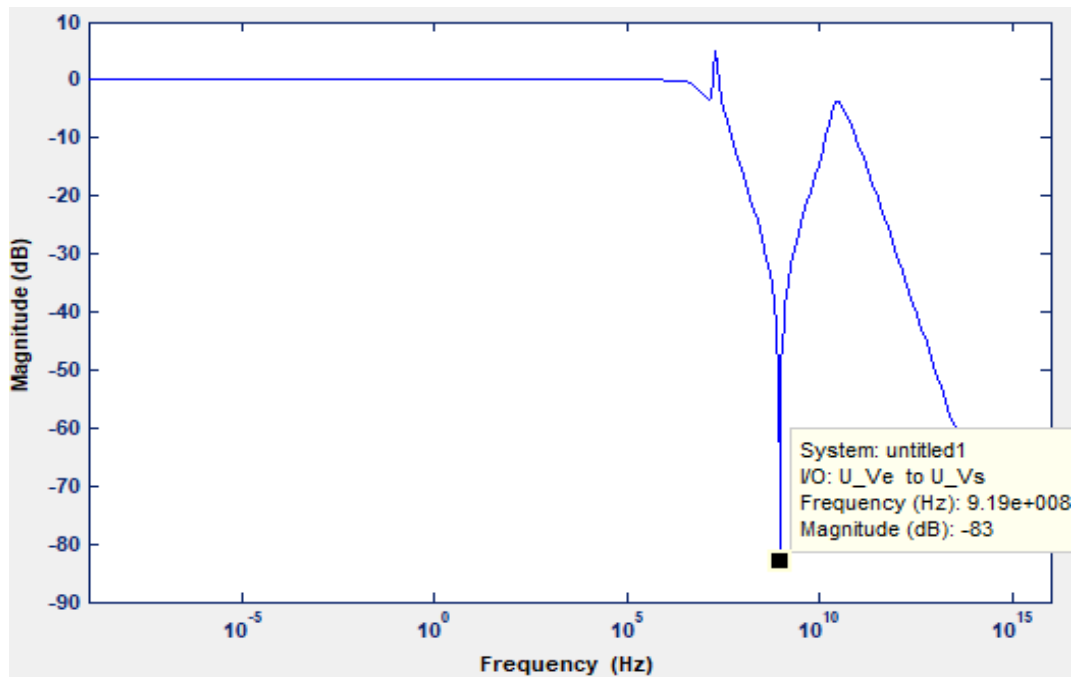

**Figure 5:** hybrid filter structure

The characteristics of the resonators are given in Table I below for resonance frequency 919 Hz:

**Table 1:** characteristics of resonators

HBAR		FBAR	
R1	5k $\Omega$	R5	1 $\Omega$
R2	1 $\Omega$	R6	1 $\Omega$
R3	5k $\Omega$	R7	1 $\Omega$
R4	1 $\Omega$	R8	1 $\Omega$
C1	1nF	C5	1nF
C2	1pF	C6	1pF
C3	0,001pF	C7	0,001pF
C4	1pF	C8	1pF
L1	90mH	L3	90mH
L2	30nH	L4	30nH
rx	0,001 $\Omega$		



**Figure 6:** hybrid structure Bode diagram

#### 4. Conclusion

Today the aim problem that arises in the evolution of the mobile telephony systems is more the improvement of the quality of service (QoS), while everything is done on the radio interface. The mobile phone system transmission chain is equipped with frequency spectrum management filters but nevertheless what we could find and analyze, we realize that the use of HBAR technology in high frequency oscillators is a good choice by the

fact that the latter has a good temperature insulation that the FBAR then in return we also insist that it has a bad occupation of the spectrum. The FBAR is exploited more in the duplexer part because it has a better selectivity of the resonance frequency but less in the high frequency oscillators in that it has poor temperature insulation. Since HBAR has an exaggerated spectrum occupancy, while an oscillator exhibits non-linear effects from the operating point of view, we can not venture to close the eye, reason we propose that the HBAR structure can be pooled with the FBAR industry-level structure during manufacturing to form a hybrid HBAR-FBAR structure; this new structure will combine the advantages of two structures, the best selectivity and the good temperature insulation. The proposed structure will contribute to improving the quality of service (QoS) in mobile telephony systems.

## **References**

- [1] SAHYOUN, Modélisation et Caractérisation linéaire et non-linéaire des filtres RF en technologie BAW et CRF et méthode pseudo-temporel de test industriel,, thèse de doctrat de l'université de GRENOBLE, 2011.
- [2] GIRAUD, Étude, conception et réalisation de résonateurs piézoélectriques pour des applications hautes fréquences, Limoges: thèse de doctorat de l'Université de LIMOGES, 2007.
- [3] VU, Contribution à la mise en œuvre de fonctions accordables à MEMS RF en bande millimétrique sur silicium, thèse de doctorat de l'Université de TOULOUSE, 2010.
- [4] HASSINE, Etude de la fiabilité des composants à ondes acoustiques de volume (BAW) pour des applications Radio Fréquence, thèse de doctorat de l'Université Joseph Fourier – Grenoble I, 2009.
- [5] SHIRAKAWA, Etude, synthèse et réalisations de filtres baw pour applications mobiles, , thèse de doctorat de l'Université BORDEAUX 1, 2006.
- [6] Yu, HBAR-Based 3.6 GHz Oscillator with Low Power Consumption and Low Phase Noise, IEEE Transactions on Ultrasonics Ferroelectrics and Frequency Control, vol. 56, n° %12, pp. 400-403, 2009.
- [7] ZEHER, Système d'Annulation d'Écho pour Répéteur Iso-fréquence, thèse de doctorat de l'université de BOURGOGNE., 2014.
- [8] FAN, Analyse et simulation de résonateurs piézoélectriques pour des applications de filtrage, Limoges: thèse de doctorat de l'Université de LIMOGES., 2009.
- [9] AISSI, Conception de circuits WLAN 5 GHZ a résonateurs BAW-FBAR intégrés : oscillateurs et amplificateurs filtrants, Toulouse, thèse de doctorat de l'université Paul Sabatier de Toulouse., 2006.
- [10] LOBL, Materials for bulk acoustic wave (BAW) resonators, Journal of the European Ceramic Society, vol. 21, pp. pp. 2633-2640, 2001.