

Modeling and Simulation of Load Frequency Control for Three Area Power System Using Proportional Integral Derivative (PID) Controller

Sat Sat Aung^{a*}, Zaw Min Htike^b

^{a,b}*Department of Electrical Power Engineering, Mandalay Technological University Mandalay, Myanmar*

^a*Email: satsataung.ep@gmail.com*

^b*Email: zawminhtike147@gmail.com*

Abstract

The impacts of three area power system restructuring on frequency regulation are simulated in this paper. A well tested classical load frequency control model to the improvement of power system operation is also presented. A robust three area power system is presented for frequency and tie-line power deviation. This simulation model is developed with and without PID controller. Using a control strategy, the system is transferred from an initial state to the final state without any oscillations in frequency and tie line power deviation. That is, the final steady state is reduced to zero error. These results are compared with and without integral controller for three area power system in terms of load disturbance in each area. For this application, MATLAB/ SIMULINK software is used.

Keywords: Load Frequency Control (LFC); Tie-line Power Flow Control; PID Controller; Three Area Power System; Automatic Generation Control (AGC).

1. Introduction

Power systems are very large and complex electrical networks consisting of generation networks, transmission networks and distribution networks along with loads. In the power system, the system load keeps changing from time to time according to the needs of the consumers. So designed controllers are required for the regulation of the system variations in order to maintain the stability of the power system and its reliable operation.

* Corresponding author.

Frequency is greatly depends on active power and the voltage greatly depends on the reactive power. The active power control and the frequency control are generally known as the Automatic Load Frequency Control (ALFC). Basically the ALFC deals with the regulation of the real power output of the generator and its frequency (speed). The primary control loop reacts to frequency changes through the speed governor and the steam flow is managed accordingly to the real power generation to relatively fast load variations. Thus maintain a megawatt balance and this primary loop performs a course speed or frequency control.

The secondary loop is slower compared to the primary loop. The secondary loop maintains the excellent regulation of the frequency. Because of the change in the active power demand/load in an area, tie-line power flows from the interconnected areas and frequency of the system changes and thus the system becomes unstable. So we need Automatic Load Frequency Control to keep up the stability at the time of the load deviations.

This is done by minimizing transient deviations of frequency in addition to tie-line power exchange and also making the steady state error to zero .Inequality involving generation with demand causes frequency deviations. If the frequency is not maintained within the scheduled values then it may lead on the way to tripping of the lines, system collapse as well as blackouts. The blades of the steam turbine and the water turbines are designed to operate at a particular speed and the frequency variations will cause change in the speed. This will lead to excessive vibration and cause damage to the turbine blades.

In the common steady state process, every power systems control area must try to counterbalance for the demand in power by the flow of tie-line power through the interconnected lines. But an area is alert of the dominance of its nearby areas by determining the flow in and flow out of power by the side of its boundaries which is commonly known as the tie-line power [1].

2. Secondary Control Loop

In an isolated power system, automatic secondary control may be implemented as a decentralized control function by adding a supplementary control loop to the turbine-governor system.

The supplementary control loop consists of an integrating element which adds a control signal that is proportional to the integral of the speed error to the load reference point. In interconnected power systems, Automatic Generation Control (AGC) is implemented in such a way that each area, or subsystem, has its own central regulator [2]. The objective of each area regulator is to maintain frequency at the scheduled level and to maintain net tie-line interchanges from the given area at the scheduled values.

If there is a large power balance disturbance in one subsystem, then regulators in each area should try to restore the frequency and net tie-line interchanges. In other words, each area regulator should enforce an increased generation covering its own area power imbalance and maintain planned net tie-line interchanges.

Area Control Error (ACE) corresponds to the power by which the total area power generation must be changed in order to maintain both the frequency and the tie-line flows at their scheduled values.

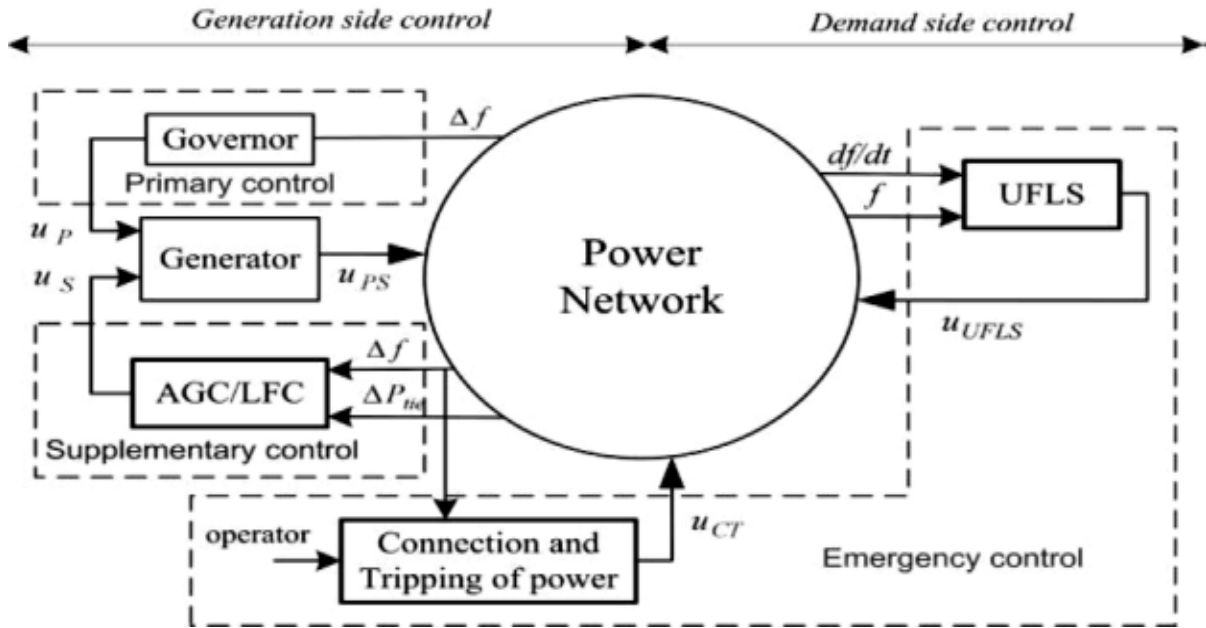

Figure 1: Power System Frequency Control Loop [4]

3. Tie-Line Interconnected Three Area Power System

Three area power system as shown in Fig (2) comprises three areas that are interconnected by high voltage transmission line or tie-lines. The trend of power frequency measured in each control area is an indicator of the trend of the mismatch power in the interconnection. The LFC system in each control area of an interconnected power system should control the interchange power with the other control areas and its local frequency. Therefore, LFC system model must be modified by taking into account the tie-line power. The system operates under three area power system, taking into consideration the change in load in each area. The model for three area power system including the secondary control loop is shown in Fig (3) below [11].

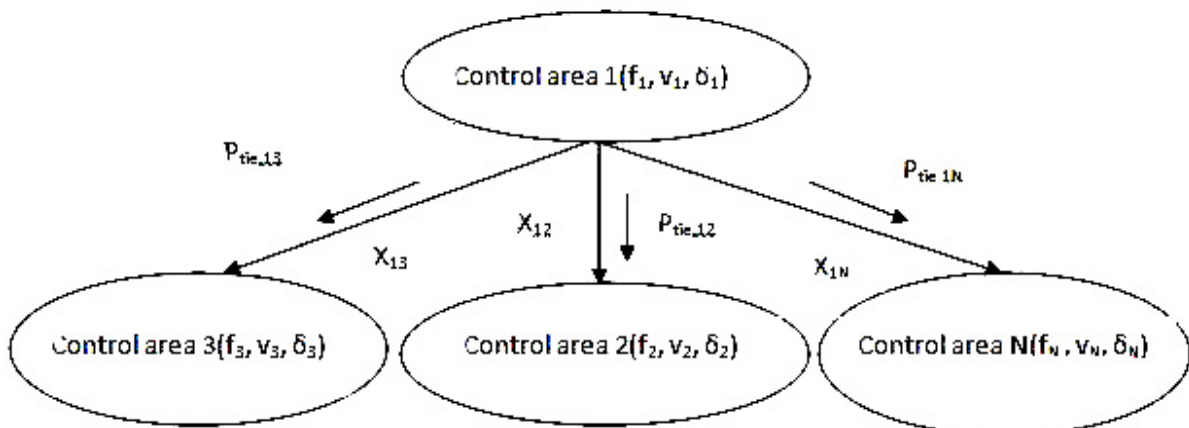

Figure 2: Multi Area Power System Control [5]

The model for three area power system including the secondary control loop is shown below. The system

operates under three area power system, taking into consideration the change in load in each area

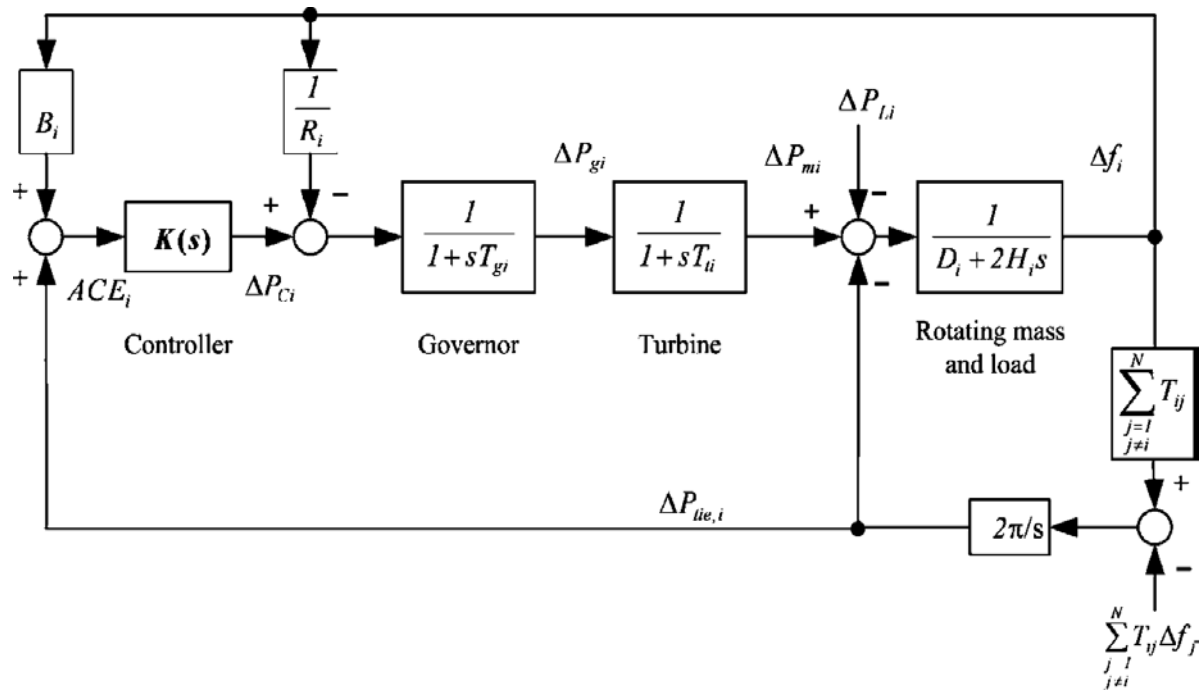

Figure 3: Control Area with Supplementary Frequency Control [5]

(I) Considering the effect of primary and secondary control s, the system frequency can be obtained as

$$\Delta f_i(s) = \frac{1}{2H_i s + D_i} [\sum_{k=1}^n \Delta P_{mki}(s) - \Delta P_{tie\ i}(s) - \Delta P_{Li}(s)] \tag{1}$$

By resolving the equation (1) into partial fraction yield,

$$\Delta f_i(s) = \Delta f_{ss,i} \tag{2}$$

By inverse Laplace transform,

$$\Delta f_i(t) = \Delta f_{ss,i} (1 - e^{-\tau_i t}) \tag{3}$$

Where, $\tau_i = \frac{D_i R_i + 1}{2H_i R_i}$

(II) Tie - line power flow among three area power system can be written as

$$P_{12} = \frac{|E_1| |E_2|}{X_{12}} \sin \delta_{12} \tag{4}$$

$$P_{23} = \frac{|E_2| |E_3|}{X_{23}} \sin \delta_{23} \tag{5}$$

$$P_{13} = \frac{|E_1| |E_3|}{X_{13}} \sin \delta_{13} \tag{6}$$

And, tie - line power deviation among three area power system can be written as

$$\Delta P_{tie\ 12} = T_{12} [\Delta \delta_1(s) - \Delta \delta_2(s)] \tag{7}$$

$$\Delta P_{tie\ 23} = T_{23} [\Delta \delta_2(s) - \Delta \delta_3(s)] \tag{8}$$

$$\Delta P_{tie\ 13} = T_{13} [\Delta \delta_1(s) - \Delta \delta_3(s)] \tag{9}$$

The Laplace transform of equations (4),(5)&(6) are

$$\Delta P_{tie\ 12}(s) = \frac{2\pi T_{12}}{s} [\Delta f_1(s) - \Delta f_2(s)] \tag{10}$$

$$\Delta P_{tie\ 23}(s) = \frac{2\pi T_{23}}{s} [\Delta f_2(s) - \Delta f_3(s)] \tag{11}$$

$$\Delta P_{tie\ 13}(s) = \frac{2\pi T_{13}}{s} [\Delta f_1(s) - \Delta f_3(s)] \tag{12}$$

$$\Delta P_{tie,i} = \sum_{j \neq i}^N \Delta P_{tie,ij} = \frac{2\pi}{s} [\sum_{j \neq i}^N T_{ij} \Delta f_i - \sum_{j \neq i}^N T_{ij} \Delta f_j] \tag{13}$$

Where, T_{ij} is the slope of the power angle curve at the initial operating angle,

$$T_{ij} = \frac{|E_1| |E_2|}{Pr1 X_{12}} \cos \Delta \delta_{120} \tag{14}$$

P_{ri} = Rated capacity of each area

$$\alpha_{12} = \frac{-P_{r1}}{Pr2} \tag{15}$$

$$\alpha_{23} = \frac{-P_{r2}}{Pr3} \tag{16}$$

$$\alpha_{13} = \frac{-P_{r1}}{Pr3} \tag{17}$$

$$\Delta P_{21} = \alpha_{12} \Delta P_{21} \tag{18}$$

$$\Delta P_{31} = \alpha_{13} \Delta P_{13} \tag{19}$$

$$\Delta P_{32} = \alpha_{23} \Delta P_{23} \tag{20}$$

(iii) For a case of three area connected via a transmission line, the change in each mechanical power is

$$\Delta P_{m1} = \frac{\Delta \omega}{R_1} \quad (21)$$

$$\Delta P_{m2} = \frac{-\Delta \omega}{R_2} \quad (22)$$

$$\Delta P_{m3} = \frac{-\Delta \omega}{R_3} \quad (23)$$

(iv) Frequency response characteristics (β) for each area

$$\beta_1 = D_1 + \frac{1}{R_1} \quad (24)$$

$$\beta_2 = D_2 + \frac{1}{R_2} \quad (25)$$

$$\beta_3 = D_3 + \frac{1}{R_3} \quad (26)$$

Thus, frequency deviation for load change of each area

$$\Delta \omega_1 = \frac{-\Delta PL_1}{\beta_1 + \beta_2 + \beta_3} \quad (27)$$

$$\Delta \omega_2 = \frac{-\Delta PL_2}{\beta_1 + \beta_2 + \beta_3} \quad (28)$$

$$\Delta \omega_3 = \frac{-\Delta PL_3}{\beta_1 + \beta_2 + \beta_3} \quad (29)$$

4. Area Control Error (ACE)

The integral control is composed of a frequency sensor and an integrator. The frequency sensor measures the frequency error and this error signal is fed into the integrator. The input to the integrator is called the area control error (ACE). ACEs are used as actuating signals to active changes in the reference power set points and when steady state is reached, ΔP_{12} and $\Delta \omega$ will be zero. ACE changes the frequency in each area and forces the steady state frequency error to zero. ACE is the combination of deviation in frequency and tie-line power. When all areas have zero ACEs, Δ net interchange and frequency deviation will be zero steady state error but frequency bias factor will work ($\beta \neq 0$). ACE measures area load change and give us good control.

If ACE <0, we must increase generation

ACE >0, we must decrease generation

ACE =0, the system is stable and no steady state error [7].

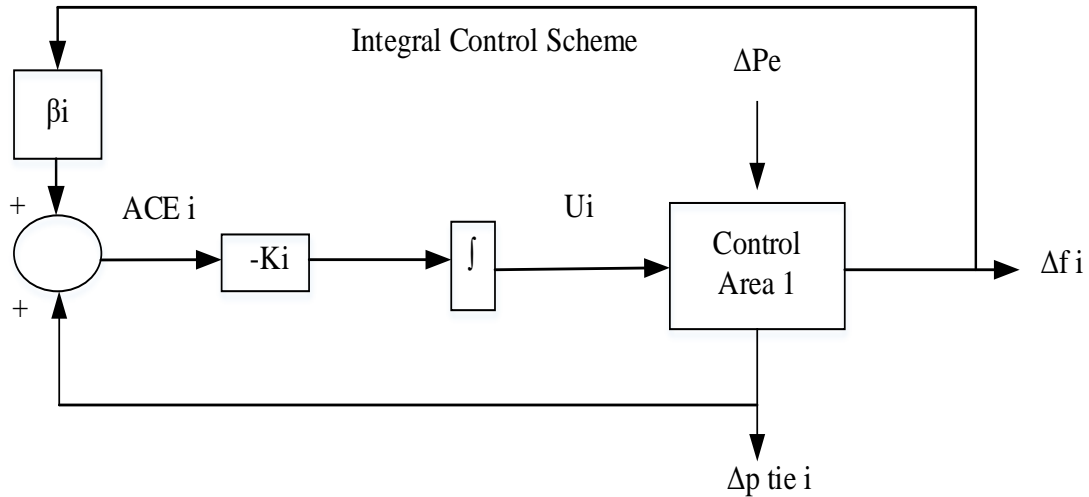

Figure 4: Area Control Error Generating System

$$ACE_1 = \Delta P_{12} + \beta_1 \Delta \omega_1$$

$$ACE_2 = \Delta P_{23} + \beta_2 \Delta \omega_2$$

$$ACE_3 = \Delta P_{31} + \beta_3 \Delta \omega_3$$

5. Proportional Integral Derivative (PID) Controller

PID controller is widely used in industrial control system as a control loop fed back. It calculates an error between the measures process variable and desired set point. PID parameters are tuned to ensure a satisfactory closed loop performance. It is used to improve the dynamic performance and to reduce the steady state error. The value of gains (K_p , K_i , K_d) are automatically achieved by tuning in Matlab simulation model. K_p is used to decrease the rise time. K_d is used to reduce the overshoot and setting time. K_i is to eliminate the steady state error. The theory of area control error related to the PID control system is as follows [6].

Proportional term, $P_{out} = K_p e(t)$

Integral term, $I_{out} = K_i \int_0^T e(t) dt$

Derivative term, $D_{out} = K_d \frac{d}{dt} e(t)$

Where, $K_p =$ Proportional gain

$K_i =$ Integral gain

$K_d =$ Derivative gain

$$U_i = K_{pi} ACE_i + K_{Ii} \int ACE_i dt + K_{di} \frac{dACE_i}{dt}$$

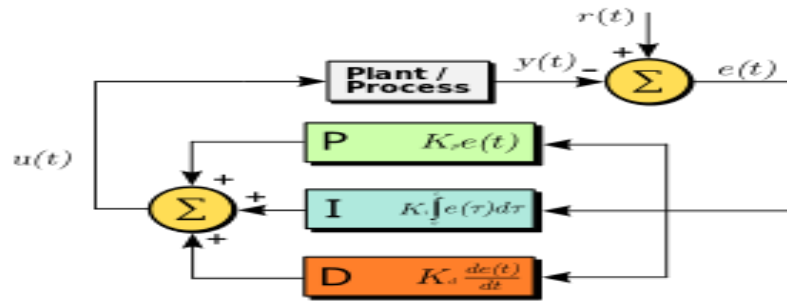

Figure 5: Conventional PID Controller [9]

6. Simulation Results

The simulation has been conducted in Matlab Simulink package for three area power system by using PID controller. Tie-line parameters for three area power system are described in Table (1) without controller and Table (2) with controller. The simulation models for three area power system without controller and with controller are shown in fig (6) and (7) respectively. In this paper the simulation performance of frequency deviation and rate of change of tie–line power flow for each areas are described. The results are shown in comparison with and without PID controller. This shows the output waveform of the system which describe the frequency deviation in terms of a sudden load change in each area. The (PID) controller is used to maintain zero steady-state errors for frequency deviation. Without using the (PID) control, the system cannot maintain zero steady–state error for long time.

Table i: Tie-line connected three area power station parameters for simulation model of without controller

Description	Area 1	Area 2	Area 3
System frequency, f	50Hz	50Hz	50Hz
Governor gain constant, K	15	20	16
Governor time constant,	0.8sec	0.3sec	0.2sec
Turbine Time Constant,	0.3sec	0.6s	0.6s
Governor Inertia Constant, H	5sec	4sec	4sec
Governor Speed Regulation, R	0.05pu	0.0625pu	0.0625pu
The Sudden Load Change, Δ_{PL}	100 MW	100MW	-
The Frequency Sensitive Load, D	1	0.6	0.9

Table ii: Tie-line connected three area power station parameters for simulation model of with controller

Description	Area 1	Area 2	Area 3
System frequency, f	50Hz	50Hz	50Hz
Governor gain constant, K	17	20	16
Proportional gain constant, K_p	0	17.8	2.5
Integral gain constant, K_i	7.53	16	5.3
Derivative gain constant, K_d	0	-4	0
Governor time constant, τ_g	0.8sec	0.2sec	0.3sec
Turbine Time Constant, τ_t	0.3 sec	0.5s	0.6s
Governor Inertia Constant, H	10sec	5sec	4sec
Governor Speed Regulation, R	0.05pu	0.0625pu	0.0625pu
The Sudden Load Change, Δ_{PL}	100 MW	100MW	-
The Frequency Sensitive Load, D	1	0.6	0.9

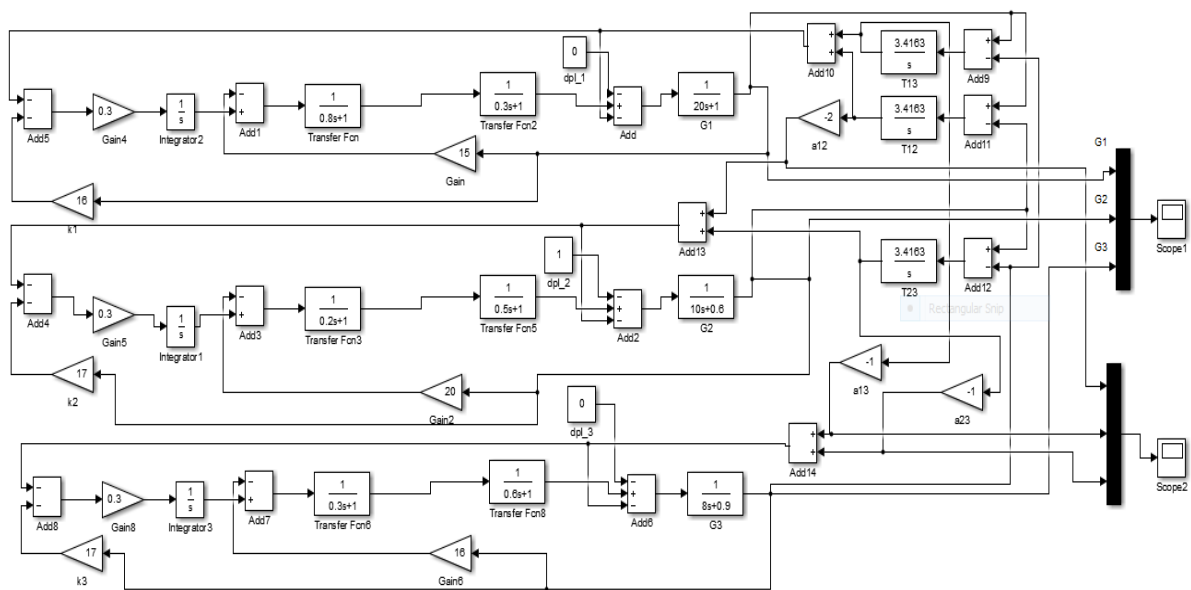

Figure 6: Simulation Model of Three Area Power System without PID controller

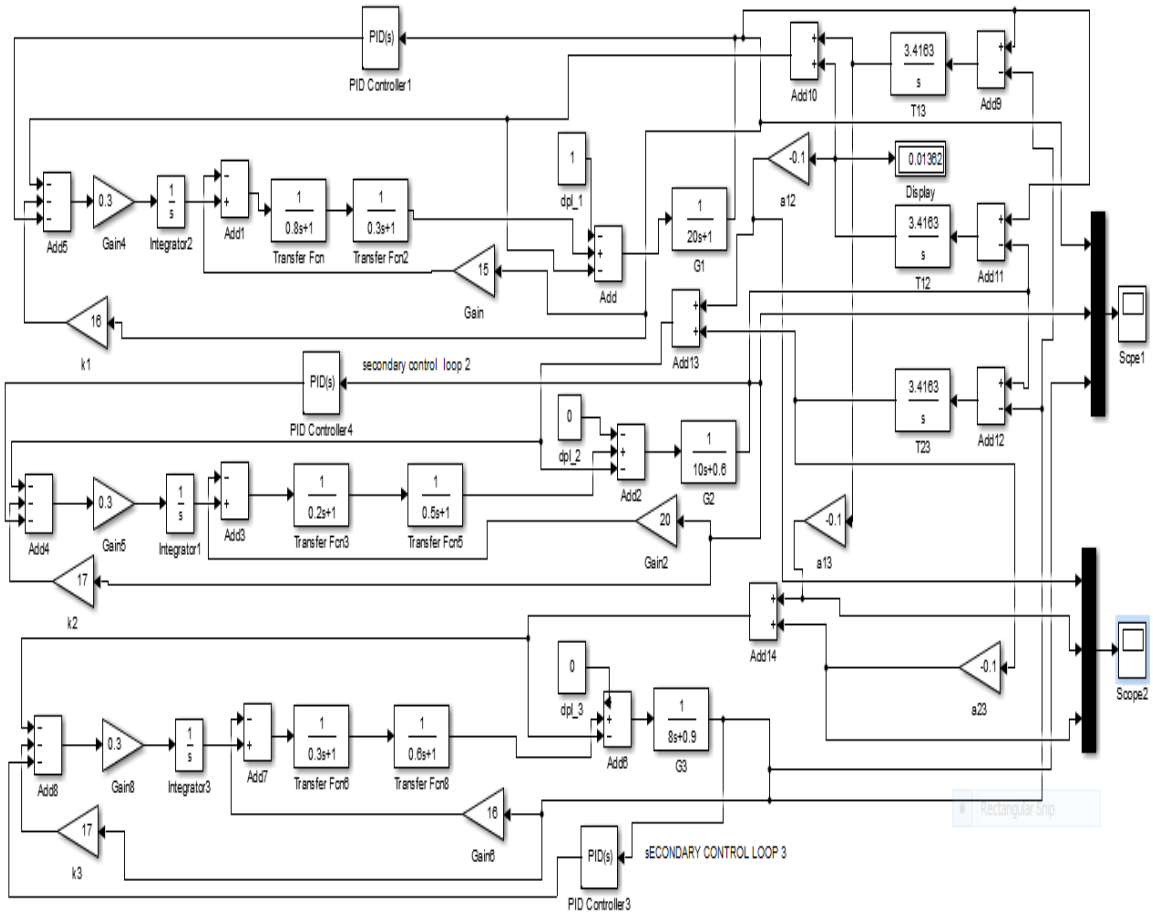

Figure 7: Simulation Model of Three Area Power System without PID controller

(A) Simulation Results of frequency Deviation for load change of area 1 with and without controller

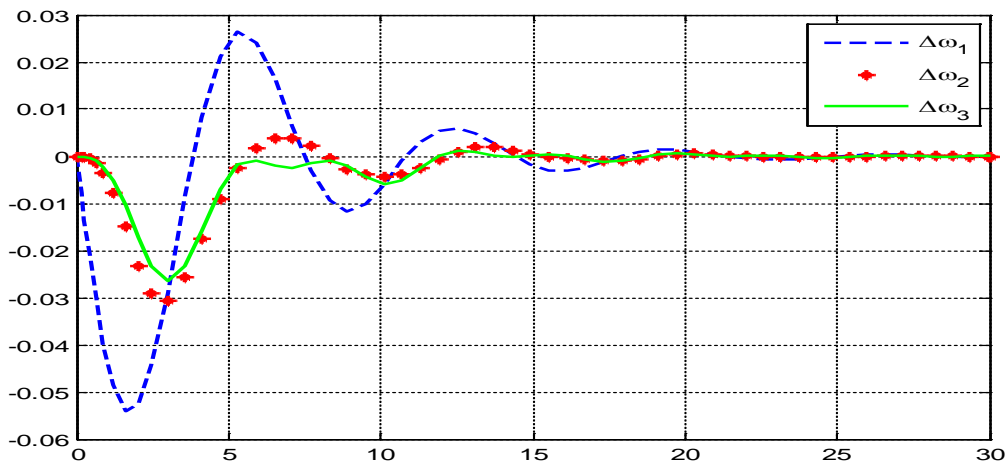

Figure 8: Three Area Frequency Deviation for Load Change of 100 MW in Area 1 without controller

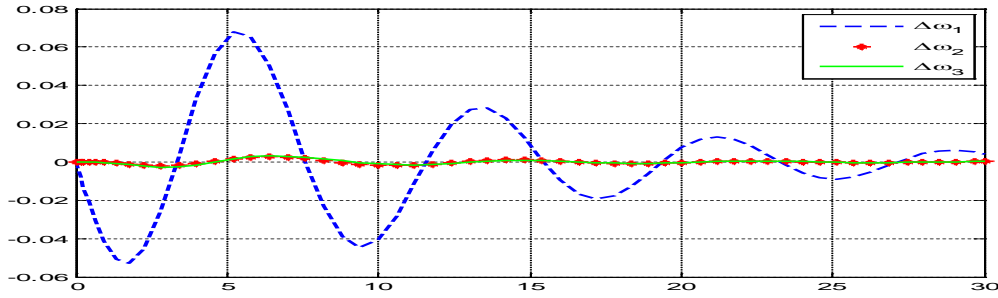

Figure 9: Three Area Frequency Deviation for Load Change of 100 MW in Area 1 with controller

Fig (8) and Fig (9) shows the comparison of frequency deviation for load change of area 1 with and without PID controller. When area 1 load is changed without using PID controller, the frequency deviations ($f_1 = 47.25Hz, f_2 = 48.5Hz, f_3 = 48.75Hz$) occur in all three areas. After using PID controller, frequency deviation occurs only in load changing area 1 and there is no frequency deviation ($f_1 = f_2 = 50Hz$) for both area 2 and area 3. PID controller gives smooth performance and reduces steady state error to maintain the nominal frequency.

(B) Simulation results of tie-line power deviation for load change of area 1 with and without controller

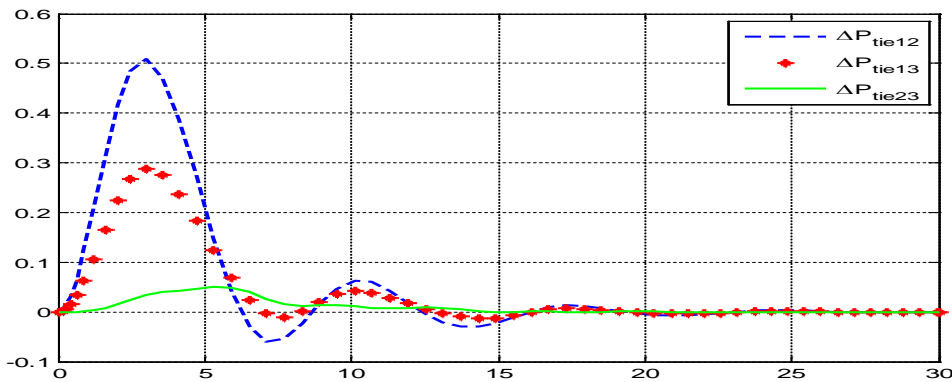

Figure 10: Three Area tie-line power deviation for Load Change of 100 MW in Area 1 without controller

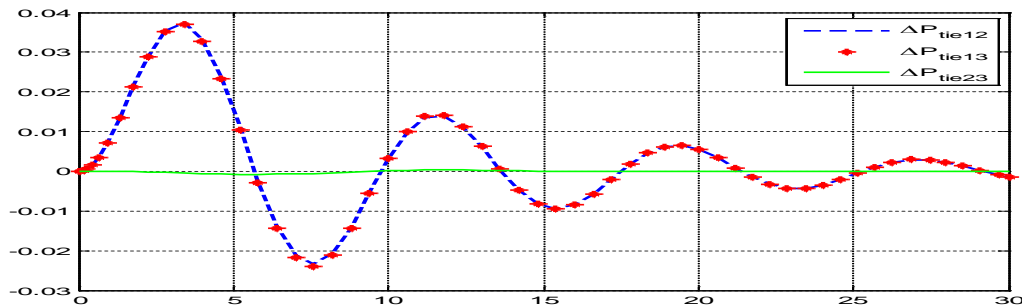

Figure 11: Three Area tie-line power deviation for Load Change of 100 MW in Area 1 with controller

Fig (10) and Fig (11) shows the comparison of tie-line power deviation for load change of area 1 with and without PID controller. When area 1 load is changed without using PID controller, the tie-line power deviation error ($\Delta P_{tie\ 12} = -0.5pu$, $\Delta P_{tie23} = 0.05 pu$, $\Delta P_{tie\ 13} = -0.3Pu$) occur in all three areas. After using PID controller, tie-line power deviation occurs only in load changing area 1 and there is no power deviation ($\Delta P_{tie\ 12} = \Delta P_{tie\ 13} = 0.035Pu$, $\Delta P_{tie23} = 0 pu$) from area 2 to area 3. PID controller gives smooth performance and reduces tie-line deviation error to zero.

(C) Simulation Results of frequency Deviation for load change of area 2 with and without controller

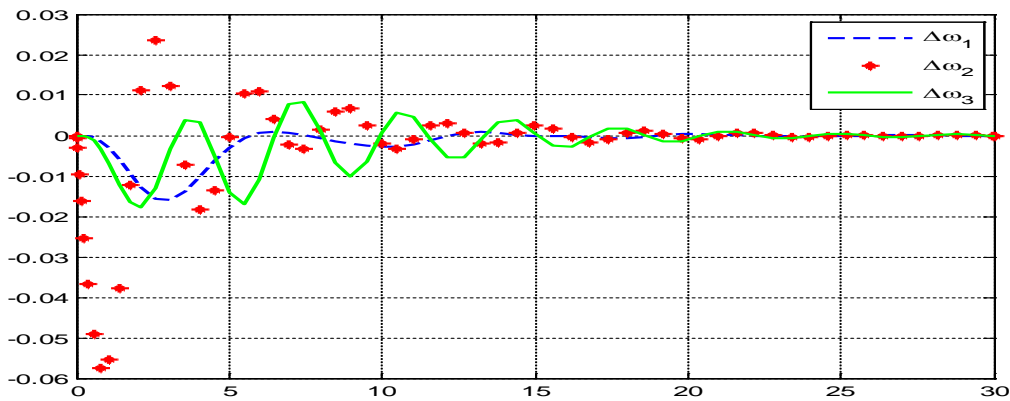

Figure 12: Three Area frequency deviation for Load Change of 100 MW in Area 2 without controller

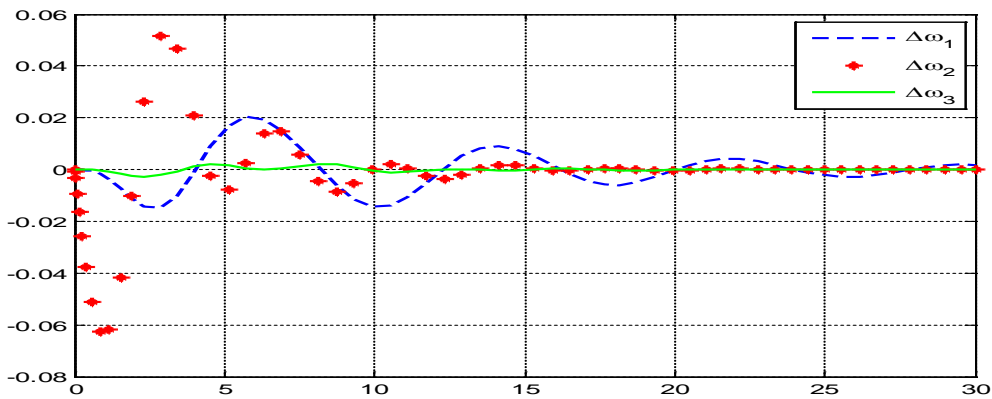

Figure 13: Three Area frequency deviation for Load Change of 100 MW in Area 2 with controller

Fig (12) and Fig (13) shows the comparison of frequency deviation for load change of area 2 with and without integral controller. When area 2 load is changed without using PID controller, the frequency deviations ($f_1 = 49.25 Hz$, $f_2 = 47.1Hz$, $f_3 = 47.1Hz$) occur in all three areas. After using PID controller, frequency deviation occurs only in load changing area 2. There is no frequency deviation ($f_3 = 50Hz$) for area 3. Area 1 frequency deviation ($f_1 = 49.6 \approx 50Hz$) nearly turns to stable. PID controller gives smooth performance and reduces steady state error to zero and finally turns to stable the neighboring areas.

(D) Simulation Results of Power Deviation for load change of area 2 with and without controller

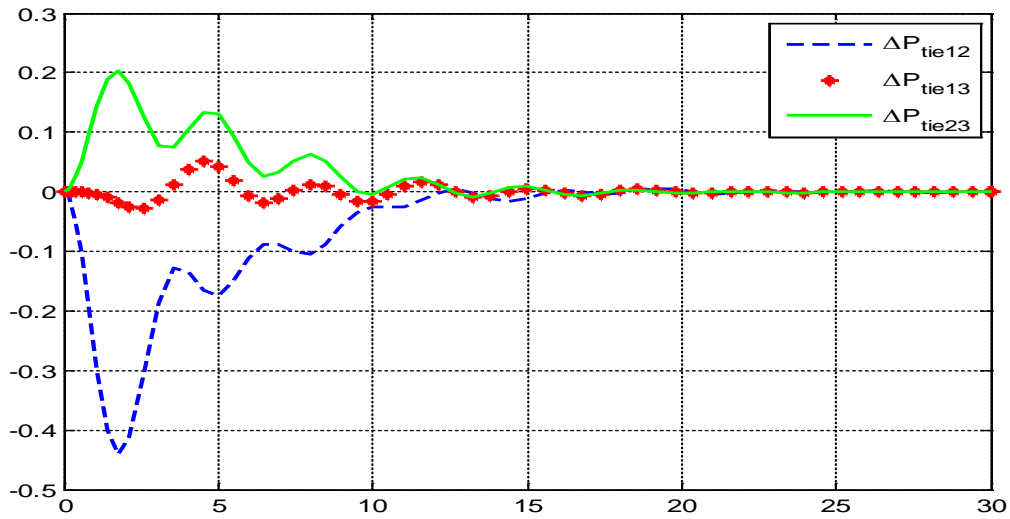

Figure 14: Three Area tie-line power deviation for Load Change of 100 MW in Area 2 without controller

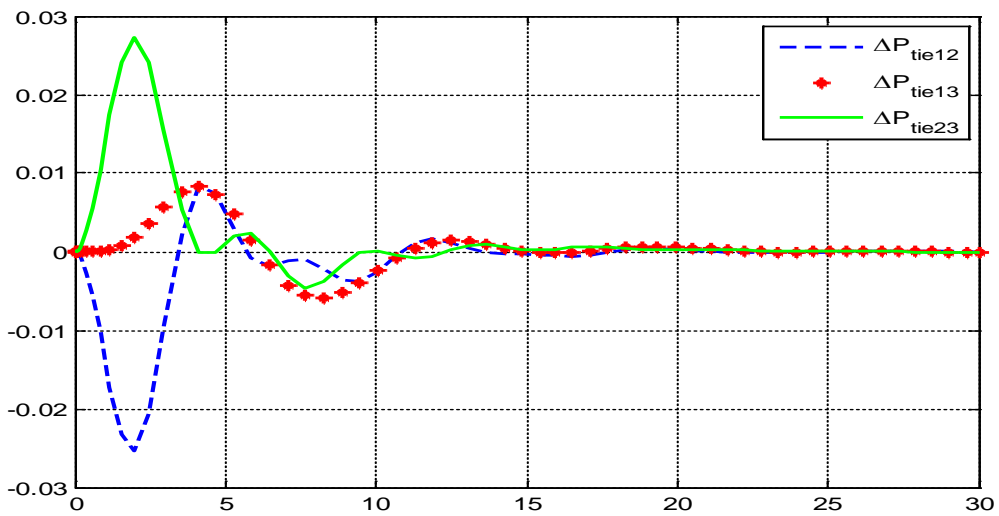

Figure 15: Three Area tie-line power deviation for Load Change of 100 MW in Area 2 with controller

Fig (14) and Fig (15) shows the comparison of tie-line power deviation for load change of area 2 with and without PID controller. When area 2 load is changed without using PID controller, the tie-line power deviation ($\Delta P_{tie\ 12} = -0.4pu, \Delta P_{tie23} = 0.2pu, \Delta P_{tie\ 13} = -0.02Pu$) and too much steady state error occur in all three areas. It takes long time to be stable operation. After using PID controller, tie-line power deviation occurs only in load changing area 2. There are small power deviations among three area power systems ($\Delta P_{tie\ 12} = -0.024 pu, \Delta P_{tie\ 23} = 0.024pu, \Delta P_{tie\ 13} = -0.009Pu$). Short time run to be stable operation. Tie-line power deviation turns to nearly zero steady state error. PID controller gives smooth performance and reduces tie-line

deviation error to zero.

7. Conclusions

In this study, the PID controller has been investigated for load frequency control of three area power system. The comparison of three area power system with and without PID controller is developed in MATLAB as shown above figures. The simulation result is shown that the control system gives smooth performance and is convenient in load frequency control. PID controller has been successfully applied to recover the system frequency to its nominal value and to control scheduled reference power of a generating unit in three area system. In this paper, the frequency variations and tie-line power deviation for three areas are described in the comparison of with and without controller. The performances of tie line flow in each area during load change are also presented as simulation result. PID control system is leading to a stable power system with zero steady state error. Modelling and simulation analysis of three area power systems are clearly described in this study.

8. Recommendation

In reliable power system, the automatic load frequency is essential. Many result papers are presented in this field for various design configuration, control methods and simulation results. Therefore, to develop the automatic load frequency control system, the conventional controller is essential. The PID controller has some weak points. These weak effects are such as taking long-time to reset the frequency and power deviation to its nominal value and getting too much variation error. To compensate these, other modern control techniques such as fuzzy logic controller, neural networks controller, genetic algorithm method and bee algorithm method are recommended for more reliable and more accurate results. The next better recommendation is to use optimal tuning method for parameter value selection and to study the second order and third order differential equations for the analysis of dynamic response of the interconnected power system.

Acknowledgment

First of all, special thanks are due to Dr. Myint Thein, Rector of Mandalay Technological University, for his motivation, supports, guidance and for giving the permission to submit this paper. The author would also like to express special thanks to Dr. Yan Aung Oo, Professor, Head of Department of Electrical Power Engineering, and Mandalay Technological University for his accomplished guidance, his willingness to share ideas in preparing this paper. Then, the author would deeply like to express gratitude to her supervisor, Dr. Zaw Min Htike, Lecturer, Department of Electrical Power Engineering, and Mandalay Technological University. Special thanks are due to for his valuable suggestions and supervision throughout the thesis, accomplished help and support, sharing ideas and experience during the research of thesis.

References

- [1] 'Automatic load frequency control of multi area power system' A thesis submitted in partial fulfillment of the requirements for the degree of master of technology in power electronics and drives by SUSHMITA EKKA.

- [2] Power System Dynamics - Stability and Control - J. Macho ski- etal. (Wiley_ 2008) WW
- [3] 'PID controller for load frequency control of three area power system / Wikipedia, the free encyclopedia'
- [4] Hassan Bevrani Takashi –University of Kurdistan ,Hiyama- Kumamoto University, "Intelligent Automatic Generation Control "International Standard Book Number-13: 978-1-4398-4954-5 (E book-PDF)
- [5] Hassan Bevrani Takashi - University of Kurdistan "Robust Power System Frequency Control, "Power Electronics and Power Systems
- [6] Tan W (2010) 'Unified Tuning of PID Load Frequency Controller for Power Systems 'via IMC.IEEE Transactions Power Systems 25(1) , 341-350.
- [7] Automatic Generation Control by Dr Ms.R Murty.
- [8] "Application of neural networks to load-frequency control in power system Francoise Beaufays, Youssef Abdel-Magid, and Benard
- [9] PID controller from Wikipedia, the free encyclopedia..
- [10] Power system analysis hadi-saadat," McGraw - Hill Series in Electrical and Computer Engineering
- [11] Automatic load frequency control of multi areas power system with intelligent generation system.