

# A Fuzzy Logic Approach for Improvement of Power Quality Using FC-TCR

Moh Moh Myint Aung<sup>a\*</sup>, Yan Aung Oo<sup>b</sup>

<sup>a,b</sup>*Department of Electrical Power Engineering, Mandalay Technological University, Mandalay, Myanmar*

<sup>a</sup>*Email: mmoe120@gmail.com*

<sup>b</sup>*Email: yanaungoo@gmail.com*

## Abstract

The reactive power compensation in a power distribution network plays a vital role in improving voltage and power system stability. The increase in the loading of the transmission lines sometimes can lead to voltage collapse due to the shortage of reactive power delivered at the load centers. This is due to the increased consumption of the reactive power in the transmission network and the characteristics of the load. All these problems can be removed by Static Var Compensator (SVC). Fixed capacitor thyristor controlled reactor (FC-TCR) can be used for power factor correction, flicker reduction, and steady-state voltage control, and also have the benefit of being able to filter out harmonics from the system. By changing firing angle of thyristor, voltage profile can be improved up to required level. The performance of FC-TCR with Fuzzy logic controller will be provided by using Matlab/Simulink. The installation site for this proposed system is Zone II Feeder of 132/33/11 kV 30MVA transformer in Tagondaing Substation.

**Keywords:** Power Quality; Power Factor; Reactive Power; Fuzzy Logic Controller; FC-TCR.

## 1. Introduction

The reactive power absorption and generation is very important since reactive power plays very important role in keeping system voltage stable. Reactive power is basically a wattless power, in order to maintain system voltage stable reactive power reserves are needed. The external mean of controlling of generation and absorption of reactive power is compensating device (shunt capacitor, series reactor), but present trend is to use power electronics device as a compensator due to their fast response and high current carrying capability.

---

\* Corresponding author.

Flexible AC Transmission Systems (FACTS) technology is based on the use of power electronic controlled devices for allowing transmission circuits to be used to their maximum capability. The FACTS devices mainly used to control the flow of reactive power and hence control voltage, phase angle, and impedance of transmission line. FC-TCR is used as a shunt compensated device for controlling the power factor of the system. The current in the FC-TCR is varied by firing angle control of thyristor, there are so many methods for controlling the firing angle of thyristor like Boolean algebra but it requires tough mathematical model and gives slow response on the other hand Fuzzy logic controller gives the accurate and fast result and does not require mathematical model. Fuzzy logic is a branch of engineering that deals with the development of computer program based on the study of human intelligence and nature of human thinking. It is argued that human thinking does not always follow crisp yes or no logic (0, 1 in boolean logic) but it often vagues uncertain indecisive or fuzzy [5]. Transmission line is segmented by keeping the sending end voltage constant. The receiving end voltage fluctuations were observed for different loads. In order to maintain the receiving end voltage constant, shunt inductor and capacitor are added for different loading conditions. SVC is simulated by means of fixed capacitor and thyristor controlled reactor (FC-TCR) which is placed at the midpoint of the transmission line. The firing angle control circuit is designed and the firing angles are varied for various loading conditions to make the receiving end voltage equal to sending end voltage. And the firing angle of FC-TCR is controlled by supplementary controller. In this system, fuzzy logic controller is used to control firing angle of thyristor [3].

## 2. Principle operation of FC-TCR type SVC

The Static Var Compensator (SVC) is a shunt connected device to exchange the reactive power for providing a dynamic control over voltages. Fixed capacitor-thyristor controlled reactor (FC-TCR) is one type of SVC to be focused in this system. It consists of parallel connection of fixed capacitors and reactor connected in series with anti-parallel thyristors and the whole assembly is connected in parallel with the transmission line midpoints or near varying loads [5].

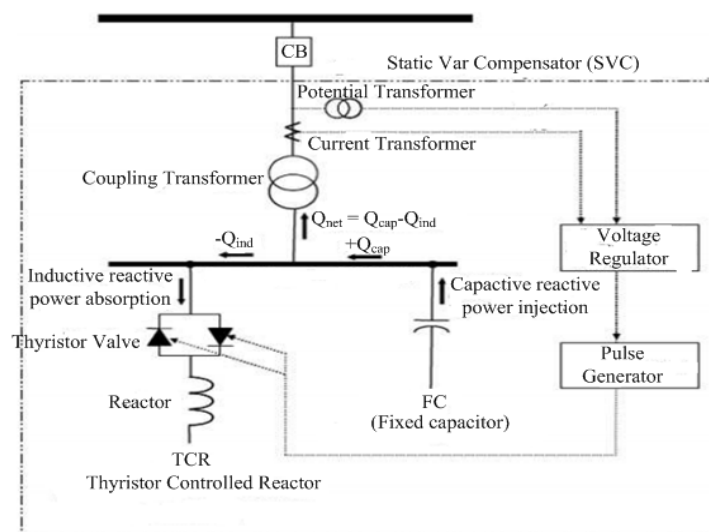


Figure 1: FC-TCR (SVC) with control concept

The control objective of the SVC is to maintain a desired voltage at the high voltage bus. In the steady-state, the SVC will provide some steady-state control of the voltage to maintain it the high-voltage bus at a pre-defined level. If sudden load is increased the high-voltage bus begins to fall below its set point, in such a condition the SVC will inject reactive power ( $Q_{net}$ ) into thereby increasing the bus voltage back to its net desired voltage level. If load falls suddenly, then bus voltage increases, the SVC (thyristor controlled reactor) will absorb reactive power, and the result will be to achieve the desired bus voltage. From Figure 1,  $+Q_{cap}$  is a fixed capacitance value, therefore, the magnitude of reactive power injected into the system,  $Q_{net}$ , is controlled by the magnitude of  $-Q_{ind}$  reactive power absorbed by the TCR. SVC is simulated by means of fixed capacitor thyristor controlled reactor (FC-TCR) [5]. Figure 2 shows the V-I characteristics and the operating area of FC-TCR. The maximum capacitive and inductive admittance are attained by the voltage and current rating of major component.

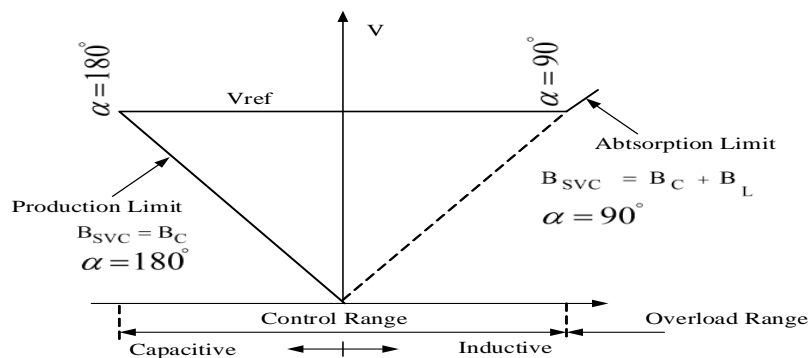


Figure 2: Operating Characteristics of the FC-TCR [8]

An SVC can improve power system transmission and distribution performance in a number of ways. Simple FC-TCR type SVC configuration is shown in Figure 1. In FC-TCR, a capacitor is placed in parallel with a thyristor controlled reactor. A basic single-phase TCR comprises an anti-parallel connected pair of thyristor valves,  $T_1$  and  $T_2$ , in series with a linear air-core reactor. The anti-parallel connected thyristor pair acts like a bidirectional switch, with thyristor valve  $T_1$  conducting in positive half-cycles and thyristor valve  $T_2$  conducting in negative half-cycles of the supply voltage. The TCR provides continuously controllable reactive power only in the lagging power-factor range. To extend the dynamic controllable range to the leading power-factor domain, a fixed-capacitor bank is connected in shunt with the TCR. The rating of TCR MVA is larger than the fixed capacitor to compensate (cancel) the capacitive MVA and provide net inductive-reactive power should a lagging power-factor operation be desired. The fixed-capacitor banks, usually connected in a star configuration, are split into more than one 3-phase group. Each capacitor contains a small tuning inductor that is connected in series and tunes the branch to act as a filter for a specific harmonic order. For instance, one capacitor group is tuned to the 5<sup>th</sup> harmonic and another to the 7<sup>th</sup>, whereas yet another is designed to act as a high-pass filter. At fundamental frequency, the tuning reactors slightly reduce the net MVA rating of the fixed capacitors. The delta connection of three single-phase TCRs prevents the triplen harmonics from percolating into the transmission line. The firing angle of the thyristors is measured from the zero crossing of the voltage appearing across its terminals. The controllable range of the TCR firing angle,  $\alpha$ , extends from  $90^\circ$  to  $180^\circ$ . The lagging reactive power (inductive reactive power) and TCR current amplitude can be controlled continuously by varying the

thyristor firing angle between  $90^\circ$  and  $180^\circ$ . The TCR firing angle can be fully changed within one cycle of the fundamental frequency, thus providing smooth and fast control of reactive power supply to the system [8].

### 3. Design of FC-TCR

The additional reactive power (Q) required at full load to maintain constant voltage at load is:

$$P_L = 8.7 \text{ MW}, \text{PF} = 0.76, \theta = 40.54^\circ$$

$$Q_{Loadmax} = P_L * (\tan \theta) \quad (1)$$

$$= 7.61 \text{ MVAR}$$

The values for the capacitor and inductor are selected by considering the reactive power demand by the load. Then, the capacitance value “C” of the capacitor bank can be determined as follows:

$$V_{bus} = 11 \text{ kV}, Q_{Loadmax} = 7.61 \text{ MVAR},$$

$$Q_{Loadmax} = V_{bus}^2 / X_C \quad (2)$$

$$X_C = \frac{1}{2\pi f C} \quad (3)$$

$$X_L = 2\pi f L \quad (4)$$

By solving Equation (3) and Equation (4), the value of inductance and capacitance are 100 mH and 200  $\mu$ F.

$$Q_{TCR}(\alpha) = Q_{FC} - Q_{load} \quad (5)$$

Where  $Q_{FC}$  is the total reactive power generated by the capacitor and is given by

$$Q_{FC} = 3.0 * V_L^2 * \omega C$$

The total reactive power absorbed by the thyristor controlled reactor is given by

$$Q_{TCR} = 3.0 * V_L * I_{TCR}$$

The current in the thyristor is related to the firing angle of the thyristor by the equation

$$I_{TCR} = \frac{V_L}{\omega L} \left( 1 - \frac{2\alpha}{\pi} - \frac{1}{\pi} \sin 2\alpha \right) \quad (6)$$

$$X_{TCR}(\alpha) = \frac{V^2}{Q_{TCR}(\alpha)} \quad (7)$$

$$X_{TCR}(\alpha) = \frac{\pi X_L}{2\pi - 2\alpha - \sin(2\pi - \alpha)} \quad (8)$$

$$B_{TCR}(\alpha) = 1/X_{TCR}(\alpha) \quad (9)$$

The per-unit value of  $B_{TCR}$  is obtained with respect its maximum value  $B_{max}$  as the base quantity.

$$B_{TCR}(\alpha) = B_{max} \left[ 1 - \frac{2\alpha}{\pi} - \frac{\sin 2\alpha}{\pi} \right] \quad (10)$$

$$B_{max} = \frac{1}{\omega L} \quad (11)$$

$$B_{SVC} = B_C + B_{TCR}(\alpha) \text{ and } B_C = \omega C \quad (12)$$

If real power consumed by SVC is zero then  $P_{SVC} = 0$ ,

$$Q_{SVC} = V^2 B_{SVC} \quad (13)$$

Where, V is bus voltage magnitude. Since reactive power is function of square of voltage hence a reactive power generated decreases as the voltage decreases.

$$I_{SVC} = V B_{SVC} \quad (14)$$

$$I_{load} = \frac{P}{\sqrt{3} V \cos \theta} \quad (15)$$

$$V_{drop} = (I_{load} + I_{SVC}) Z_{tr} / 2 \quad (16)$$

$$V_{bus} = V_{ref} - V_{drop} \quad (17)$$

The fixed capacitors are replaced by LC filter to eliminate third and fifth harmonics in the supply current LC filter tuned to third and fifth harmonic are designed [11].

At third harmonic frequency:

$$L_3 = \frac{1}{4} \times \frac{1}{\omega^2 C} \quad (18)$$

$$C_3 = \frac{4}{9} \times C \quad (19)$$

At fifth harmonic frequency:

$$L_5 = \frac{1}{12} \times \frac{1}{\omega^2 C} \quad (20)$$

$$C_5 = \frac{12}{25} \times C \quad (21)$$

#### 4. Load Data for Proposed System

The load data for Zone II Feeder of 132/33/11 kV (30 MVA) transformer in Tagondaing Substation is shown in table 1.

#### 5. Fuzzy Logic Controller

The fuzzy logic controller provides firing angle obtained from the PF angle of the load to FC-TCR. LC filters are also used in conjunction to maintain stability. With the use of TCR, the reactive power is absorbed, and it is compensated by injection of reactive power from FC as shown in Figure 3. Fuzzy logic is a suitable intelligent technique to provide PFC.

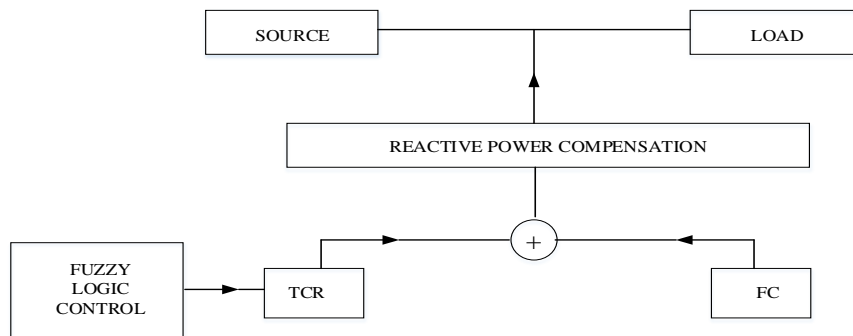


Figure 3: Fuzzy based FC-TCR [9]

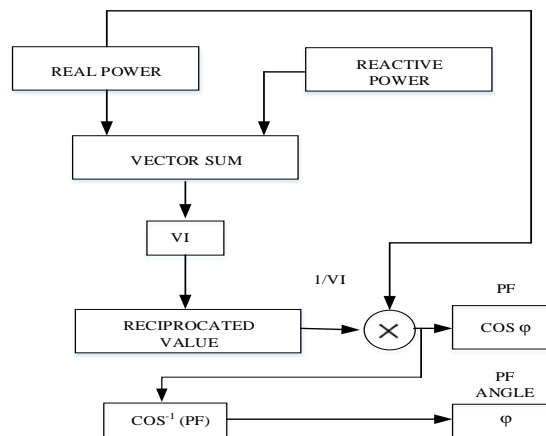


Figure 4: Calculation of PF and PF Angle

Thus, the voltage gets stabilized when the reactive power is injected or absorbed into the line between source and load. The PF rises as the reactive power reduces.

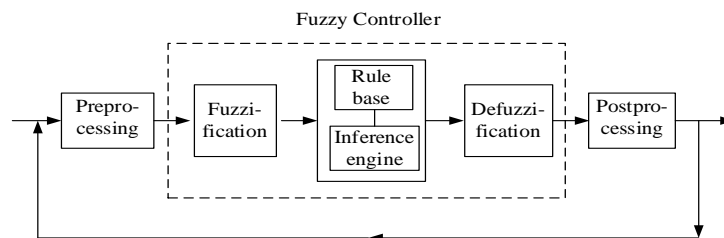
**Table 1:** Load data for zone II Feeder of 132/33/11 kV (30 MVA) transformer in Tagondaing Substation for 24 Hours

			$P_L$	$Q_L$	$Q_{TCR}(\alpha)$	$X_{TCR}(\alpha)$	$\alpha$
Time	PF	PF Angle	(MW)	(MVA <sub>r</sub> )	(MVA <sub>r</sub> )	$\Omega$	( $^\circ$ )
1	0.72	43.95 $^\circ$	6.4	6.17	1.44	84.03	144.44 $^\circ$
2	0.74	42.27 $^\circ$	5.9	5.36	2.25	53.78	126.11 $^\circ$
3	0.78	38.74 $^\circ$	5.5	4.41	3.2	37.81	104.68 $^\circ$
4	0.8	36.87 $^\circ$	5.6	4.2	3.41	35.48	99.92 $^\circ$
5	0.8	36.87 $^\circ$	6.8	5.1	2.51	48.21	120.26 $^\circ$
6	0.85	31.79 $^\circ$	8.3	5.14	2.47	48.99	121.18 $^\circ$
7	0.85	31.79 $^\circ$	8.4	5.21	2.4	50.42	112.74 $^\circ$
8	0.76	40.54 $^\circ$	8.9	7.61	0	$\infty$	180 $^\circ$
9	0.78	38.74 $^\circ$	8	6.42	1.19	101.68	150.06 $^\circ$
10	0.81	35.9 $^\circ$	8.1	5.86	1.75	69.14	137.41 $^\circ$
11	0.82	34.92 $^\circ$	7.3	5.1	2.51	48.21	120.26 $^\circ$
12	0.84	32.86 $^\circ$	7.7	4.97	2.64	45.83	117.33 $^\circ$
13	0.84	32.86 $^\circ$	7.3	4.72	2.89	41.87	110.12 $^\circ$
14	0.84	32.86 $^\circ$	6.9	4.46	3.15	38.41	105.81 $^\circ$
15	0.82	34.92 $^\circ$	7.3	5.1	2.51	48.21	120.26 $^\circ$
16	0.8	36.87 $^\circ$	7.7	5.78	1.83	66.12	135.6 $^\circ$
17	0.8	36.87 $^\circ$	7.7	5.78	1.83	66.12	135.6 $^\circ$
18	0.78	38.74 $^\circ$	8.6	6.7	0.91	132.97	156.38 $^\circ$
19	0.85	31.79 $^\circ$	8.7	5.4	2.21	54.75	127.04 $^\circ$
20	0.87	29.54 $^\circ$	8.6	4.87	2.74	44.16	115.08 $^\circ$
21	0.91	24.49 $^\circ$	8.1	3.69	3.92	30.87	90 $^\circ$
22	0.87	29.54 $^\circ$	8.1	4.59	3.02	40.07	108.75 $^\circ$
23	0.83	33.9 $^\circ$	7.1	4.77	2.84	42.61	112.82 $^\circ$
24	0.84	32.86 $^\circ$	6.4	4.13	3.48	34.77	98.38 $^\circ$

The PF angle of the load given as input to the fuzzy logic controller to produce a firing angle is calculated from Figure 4. The fuzzy inference system provides firing angle as per framed fuzzy rules. This firing angle given to the firing pulse generator provides pulses for FC-TCR. The PF value can be observed by setting different values for real and reactive power. The increase in PF value is noted in all cases [9]. Fuzzy logic control is one of the control algorithm based on a linguistic control strategy, which is being derived from expert knowledge into an automatic control strategy. Fuzzy logic control doesn't need any kind of difficult mathematical calculation like the other control systems. While the other types of control system use difficult mathematical calculation to provide a model of the controlled plant, fuzzy uses only simple mathematical calculation to simulate the expert knowledge. Although it doesn't need any difficult mathematical calculation, but it gives a good performance in a control system. Thus, it can be one of the best available answers today for a broad class of challenging controls problems.

Principal components of Fuzzy logic controller are:

1. Fuzzification block or fuzzifier
2. Knowledge base
3. Decision making block
4. Defuzzification block or defuzzifier



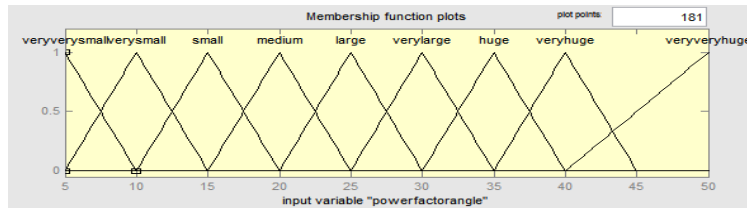
**Figure 5:** Develop Fuzzy Controller [1]

Fuzzification is the process of making a crisp quantity fuzzy. The input signal is then fuzzified into linguistic variables like small positive, large positive, zero, small negative, large negative. The linguistic quantification is used to specify a set of rules called a rule-base. The general form of the rules is IF premise THEN consequent. In inference mechanism the premises of all the rules are compared to the inputs to determine which rules apply to the current situation. After this matching process the required rules are fired. The output of a Fuzzy rule based system is generally imprecise and Fuzzy. As a Fuzzy set cannot directly be used to take the decisions, the fuzzy conclusions of rule based systems have to be converted into precise quantity. This is called Defuzzification. There are various methods like centroid method, weighted average method and max-membership method etc for this purpose.

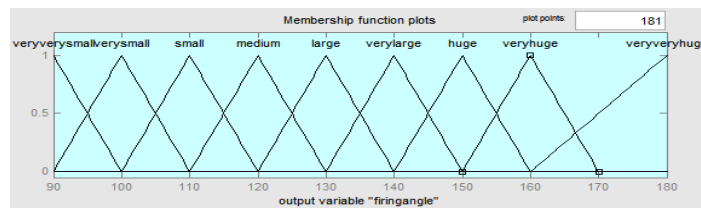
This paper uses a Mamdani-type fuzzylogic system for firing angle of TCR. The trapezoidal and triangular



membership functions are the most widely used functions because of their simple formula and efficiency in computation. In this paper triangular membership function is used since it is the simplest one and requires less data. The Y value of the membership function is always set on a range of 0 to 1 (theoretically 0 to 100%). The X value of the membership function will be an arbitrary range that is determined. According to the table 1, the X value of the input membership function is taken from 5 to 50 in Figure 6 and The X value of the output membership function is taken from 90 to 180 in Figure 7. The rule based developed for fuzzy controller is as shown in Figure 8. Which rules apply to the current situation can be seen by using the rule viewer shown in the Figure 9.

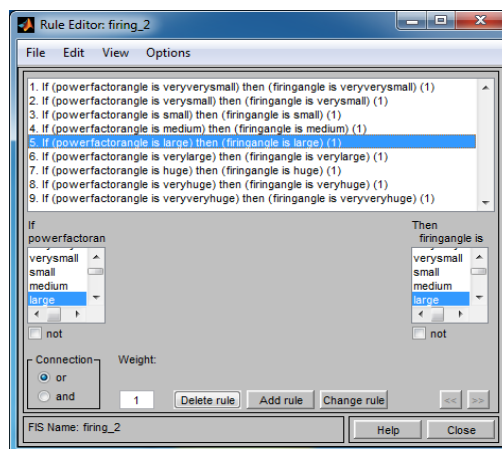


**Figure 6:** Membership function for input variable



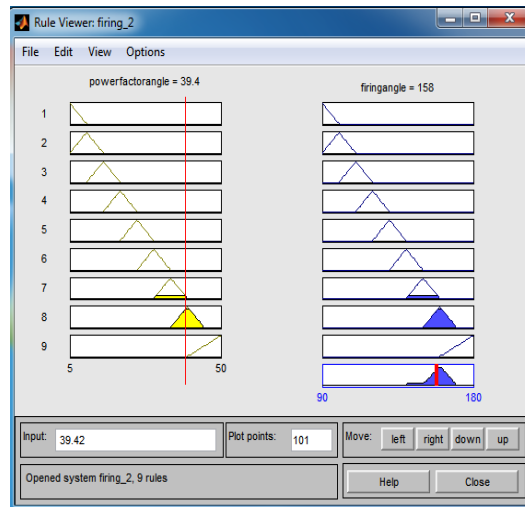
**Figure 7:** Membership function for output variable

The space of one of the input variable, i.e., power factor angle, is partitioned into nine fuzzy subsets, namely: veryverysmall (VVS), verysmall (VS), small (S), medium (M), large (L), verylarge (VL), huge (H), veryhuge (VH) and veryveryhuge (VVH). Similarly The space of the output variable i.e., firing angle of TCR is partitioned into six fuzzy subsets similar to that of power factor angle.



**Figure 8:** List of Fuzzy rules

FLC is a rule based controller, where a set of rules represents the control decision mechanism which controls the calculation of optimal firing angle. Rules are constructed for each fuzzy subsets of input.



**Figure 9:** Rule Viewer for the Develop Fuzzy Controller

Mamdani based Fuzzy logic interfacing rule is adopted for correction of power factor. Complex power is taken from power measuring block, in which power angle is taken as input of Fuzzy controller. According to power angle control output (firing angle) is provided by Fuzzy controller. When power angle is large firing angle is also large. Controlled output is supplied to variable delay circuit and it is supplied to thyristor. According to the output of variable time delay circuit firing angle of thyristor is changed.

It is supposed to control reactive power by controlling the firing angle of TCR, for effective control over firing angle, Fuzzy logic controller is used [3]. FC-TCR with Fuzzy controller is able to maintain the power factor always constant at receiving end under normal condition as well as at large inductive load and does not affect with load variations.

## 6. Simulation Model and Results of Proposed System

This system is composed by a 33 kV, 50 Hz distribution system from 30 MVA 132/33/11 kV step down transformer. And it is supplied to zone (2) feeder and other three feeders. System parameter of 132/33/11 kV (30 MVA) transformer in Tagondaing Substation is expressed in table 2.

Figure 10 presents the simulation diagram of the grid connected inductive load compensated by FC -TCR which is incorporated as the power factor correction. Two inductive loads at Zone II Feeder are switched in different times.

Local load (1.65 MW) of Zone II Feeder is switched on at  $t = 0.4$  s and switched off at  $t = 1.2$  s and industrial load (2 MW) of Zone II Feeder is switched on at  $t = 0.8$  s and switched off at  $t = 1.6$  s. Other three Feeders: Air-port (SB), Air-port (pri) and Sagaing (1) feeder loads are used as fixed load in this system.

**Table 2:** System parameter of 132/33/11 kV (30 MVA) transformer in Tagondaing Substation

System Quantities	System Parameters
Source	Three-phase 132 kV, 50 Hz
Main Transformer	30 MVA 132 / 33 / 11 kV Delta / Star / Star ground
Coupling Transformer	10 MVA 33 / 11 kV
Inductor size of TCR	100 mH
Capacitor size of FC	200 $\mu$ F
LC filters	$C_3 = 89 \mu\text{F}$ , $L_3 = 0.0127$ , $C_5 = 97\mu\text{F}$ , $L_5 = 4.218\text{mH}$
Load Parameters	
Industrial zone II Feeder Load	$P = 8.03 \text{ MW}$ , $Q = 6.87 \text{ MVAR}$ (7.242 km)
Non Linear Load	$0.213 \Omega$ , $6.79 \text{ e}^{-3} \text{ H}$
Station Load	$P = 0.5 \text{ MW}$ , $Q = 0.25 \text{ MVAR}$
Other Feeders	
Air-port (SB) Load	$P = 0.2 \text{ MW}$ , $Q = 0.14 \text{ MVAR}$ (29.637 km)
Air-port (pri) Load	$P = 0.8 \text{ MW}$ , $Q = 0.56 \text{ MVAR}$ (28.646 km)
Sagaing (1) Load	$P = 6.5 \text{ MW}$ , $Q = 5.375 \text{ MVAR}$ (11.378 km)

In this simulation, FC-TCR is used as a compensation device and its excess amount of reactive power is absorbed by the reactor. Further, the detail controlling of the reactor in the simulation is addressed by the firing angle control of thyristor. A Fixed capacitor also provides reactive power in the system which enhances the power factor correction framework. Due to fast response and high accuracy fuzzy logic controller, it is used in order to control the firing angle of the thyristor used in FC-TCR. The fuzzy controller accepts the phase angle

difference of the load as an input and output is taken as the optimum firing angle of TCR.

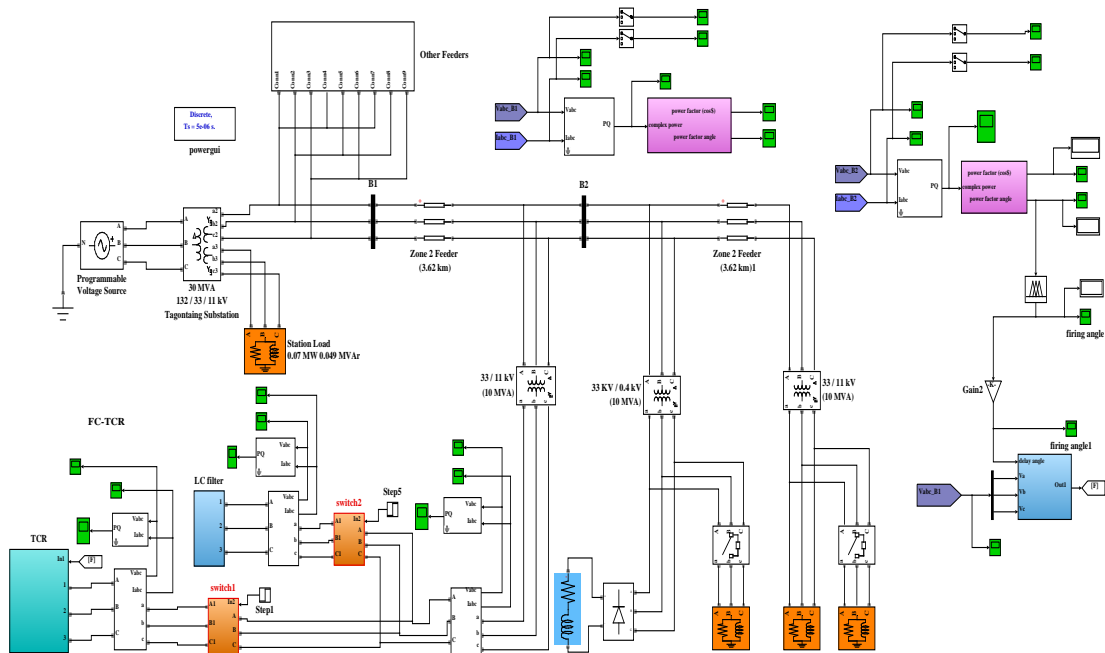


Figure 10: Simulation model of distribution system with Fuzzy Logic Controlled FC-TCR

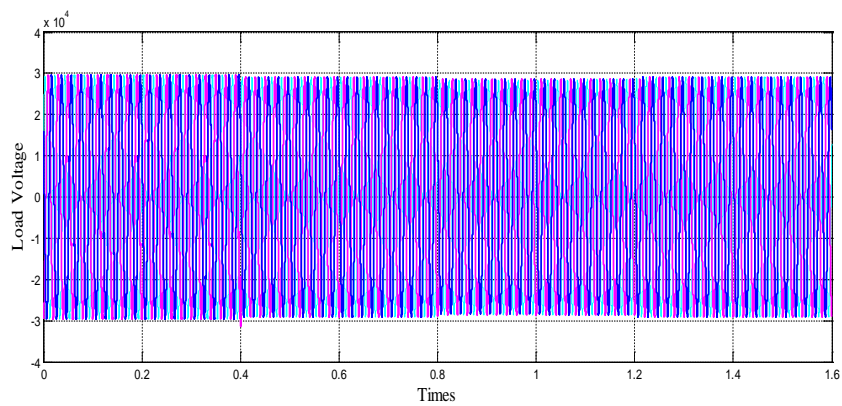


Figure 11: Simulation result of load voltage without compensation

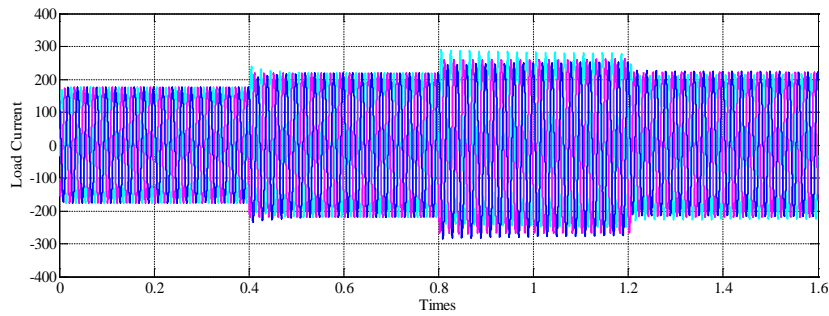
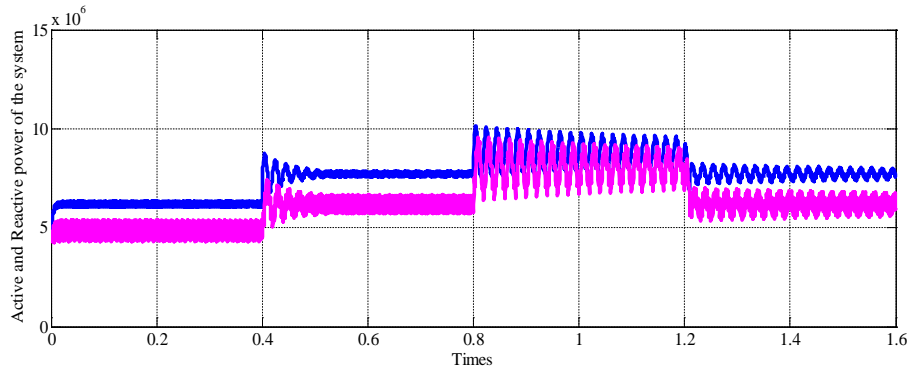
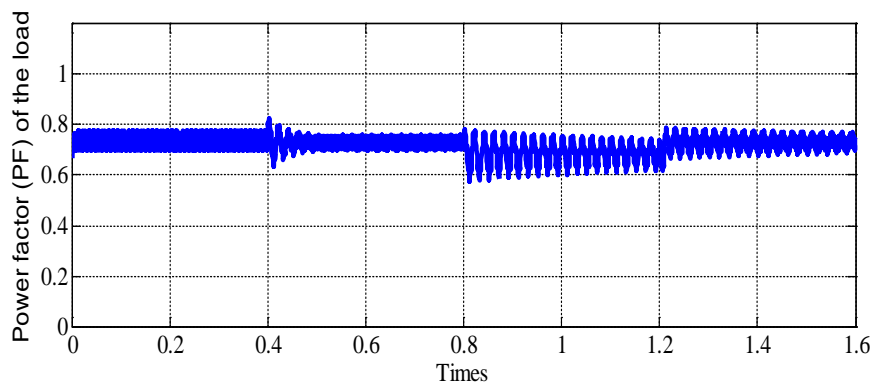


Figure 12: Simulation result of load current without compensation

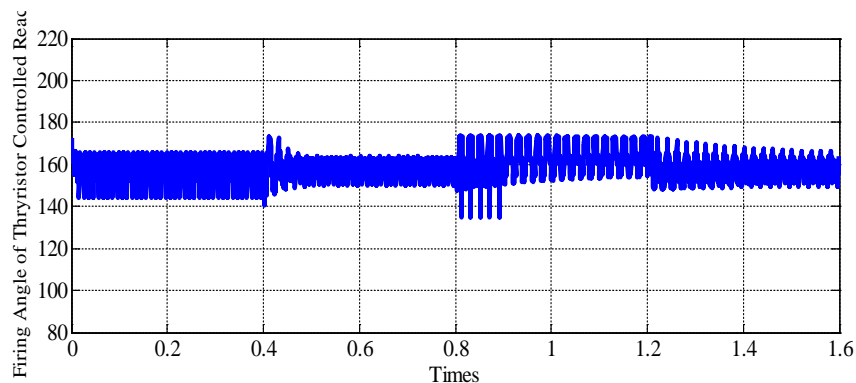


**Figure 13:** Simulation result of active and reactive power at load end without compensation



**Figure 14:** Power Factor of the load without compensation

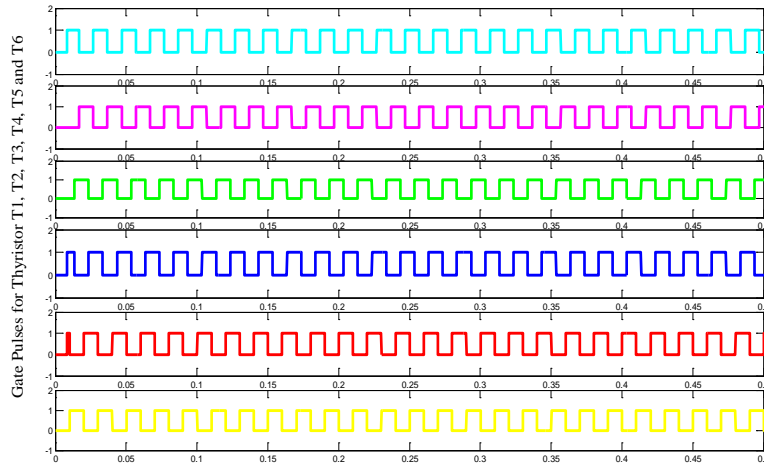
Figure 13 shows the active and reactive power at load side without compensation. As shown in this Figure 14, from  $t = 0.4$  s to  $t = 0.8$  s, reactive power increases and power factor (PF) decreases by inductive load increasing. Also at  $t = 1.2$  s one of inductive loads retreat from power system and therefore power factor increases and inductive load decreases.



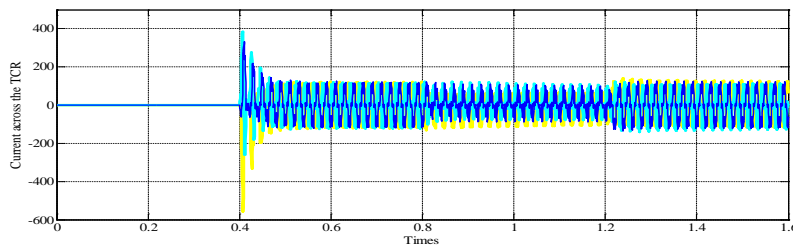
**Figure 15:** Simulation result of firing angle variation

In Figure 15, the control output firing angle of thyristor control reactor is varied according to input power factor angle by Fuzzy controller. The output of variable time delay is used for firing angle control of thyristor. The

variation of gate pulses of thyristor control reactor during positive half and negative half-cycle is shown in Figure 16.

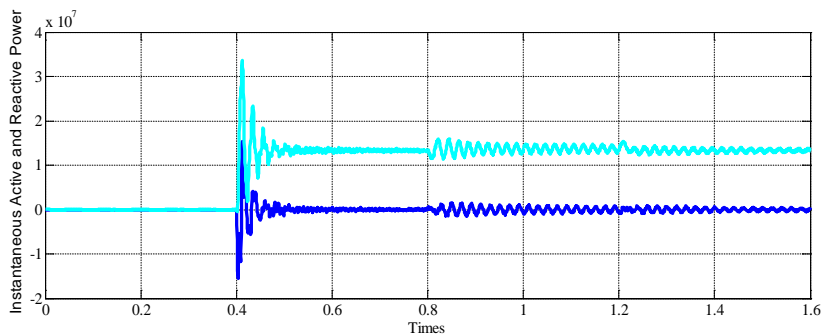


**Figure 16:** Simulation result of Gate pulses for Thyristor T<sub>1</sub>, T<sub>2</sub>, T<sub>3</sub>, T<sub>4</sub>, T<sub>5</sub> and T<sub>6</sub>

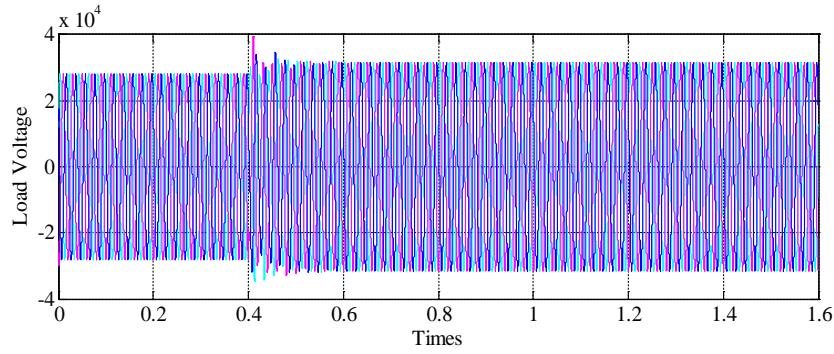


**Figure 17:** Simulation result of three phase current across TCR

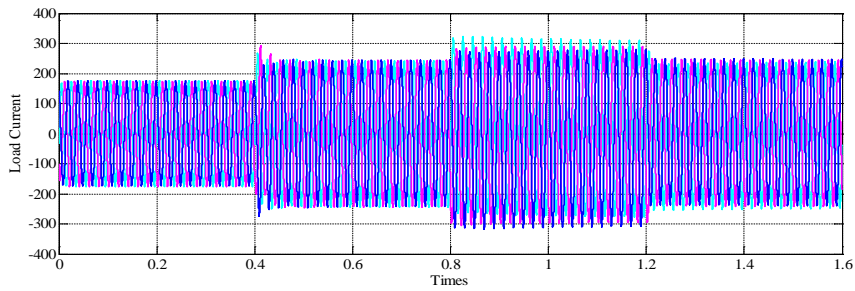
Simulation result of three phase current across TCR is shown in Figure 17. Thyristor controlled reactor (TCR) stage to provide the lagging vars. The lagging reactive power (inductive reactive power) and TCR current amplitude can be controlled continuously by varying the thyristor firing angle between  $90^\circ$  and  $180^\circ$ . The TCR firing angle can be fully changed within one cycle of the fundamental frequency, thus providing smooth and fast control of reactive power supply to the system.



**Figure 18:** Simulation result of Instantaneous power of FC-TCR

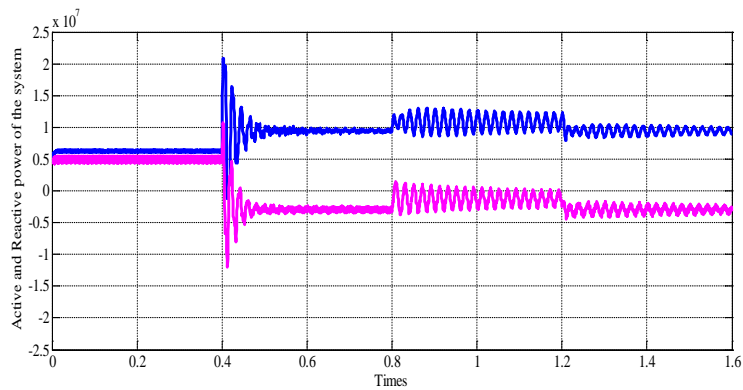


**Figure 19:** Simulation result of load voltage with compensation

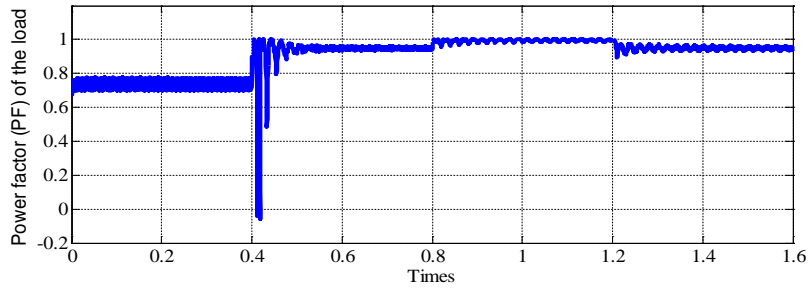


**Figure 20:** Simulation result of load current with compensation

Figure 11, Figure 12, Figure 19 and Figure 20 show the simulation results of load voltage and load current with and without compensation by FC-TCR. At starting, the load voltage is nearly 30 kV due to certain inductive is injected into the system. Local load (1 MW) of Zone II Feeder is switched on at  $t=0.4s$  and switched off at  $t=1.6$  s the load voltage is decreased below 30 kV and the load current is increased over 200 A. After 0.8 s, industrial load (2 MW) of Zone II Feeder is switched on again, the load voltage is more decreased and the load current is more increased. At  $t=1.2$  s, load 2 is switched off. At that time, the load voltage is increased and the load current is decreased again. But, after 0.4 s, FC-TCR is connected to the system and due to this, the required voltage is attained and the voltage is become stable.



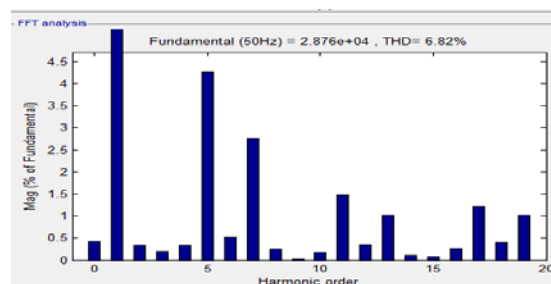
**Figure 21:** Simulation result of active and reactive power at load end with compensation



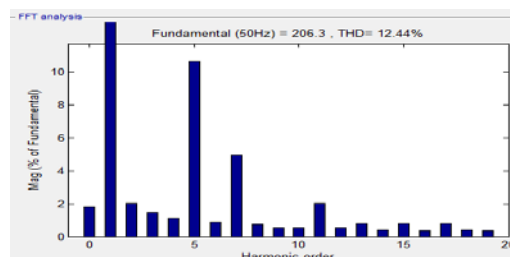
**Figure 22:** Power factor improvement of the load with compensation

As shown in Figure 21 and Figure 22, it is clear that the FC-TCR compensated the load active and reactive power demands up to an encouraging level. The effect of the reactive power demand has been successfully achieved. Moreover, the FC-TCR has compensated the system with proper and adequate compensation for reactive power. Thus, the power factor of the system increased from 0.76 to near unity and simultaneously power quality of the system is also improved. FC-TCR with Fuzzy controller is able to maintain the power factor always constant at receiving end under normal condition as well as at large inductive load and does not affect with load variations.

The total harmonic distortion (THD) causes adverse effects to inductive loads. Thus, THD of load voltage and current with and without compensation are studied with FFT analysis. The FFT analysis of load voltage and current without using the LC filter is performed in Figure 23 and Figure 24 which mention that the THD of load voltage and current are 6.82% and 12.44% respectively. The fixed capacitors are replaced by LC passive filter to eliminate third and fifth harmonics. Attenuation of these harmonics is achieved by an LC passive filter as presented in the simulink model.



**Figure 23:** FFT analysis of  $V_{load}$  without FC-TCR compensation



**Figure 24:** FFT analysis of  $I_{load}$  without FC-TCR compensation



In Figure 25 and Figure 26, the FFT analysis of load voltage and current is observed after using FC-TCR with fuzzy logic controller of which THD shows 1.8% for  $V_{load}$  and 3.22% for  $I_{load}$ . It is clear that the FC-TCR with fuzzy logic controller is able to reduce THD of load voltage and current to over 50%.

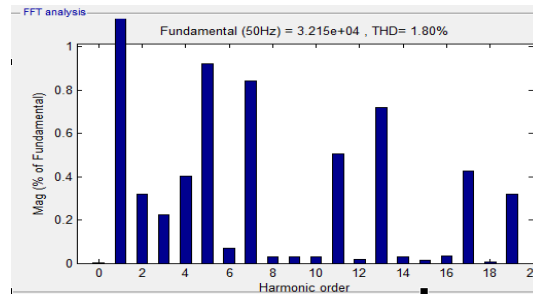


Figure 25: FFT analysis of  $V_{load}$  with FC-TCR compensation

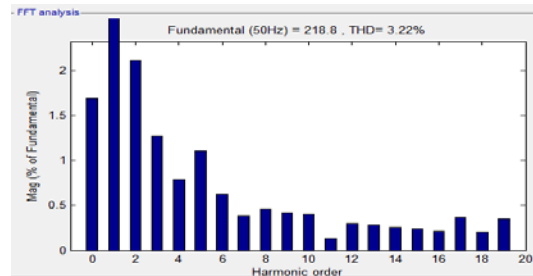


Figure 26: FFT analysis of  $I_{load}$  with FC-TCR compensation

## 7. Conclusions

Simulation results show a good performance of fuzzy controller in power factor correction and reactive power compensation. It is observed that FC-TCR device is able to compensate both over and under voltages. The use of Fuzzy logic has facilitated the closed loop control of system, by designing a set of rules, which decides the firing angle given to the thyristor to attain the required voltage. With Matlab/ simulations it is observed that FC-TCR provides an effective reactive power control irrespective of load variation and also provides voltage stability. It can be observed that the power factor of the system is increased from 0.8 to near unity. Also the reactive power is reduced from 4.5 MVAR to - 0.1 MVAR in the case of first load and from 6.2 MVAR to zero for the second load. In addition, the total harmonic distortion can be reduced to 1.8% and 3.22% respectively for load voltage and current by including FC-TCR with fuzzy logic controller and modifying the system parameters.

## Acknowledgements

The author would like to thank to Dr. Yan Aung Oo, Professor, Head of Department of Electrical Power Engineering, Mandalay Technological University, for his kind permission, providing encouragement and giving helpful advices and comments. The author wishes to thank to all of her teachers from Mandalay Technological University. The author's special thanks are sent to her parents, brother and friends for their support and encouragement.

## References

- [1] "Fuzzy Logic Toolbox" Simulink/ Matlab.
- [2] "Reactive Power Control Using FC-TCR", International Journal Of Innovative Technology And Research, Vol.1, Issue no. 1, Dec-Jan -2013, 037-041. N.V.
- [3] "Deepank Agnihotri and Dr. Samina E. Mubeen, "Fuzzy Optimization For Power Quality (Power Factor) Improvement Using FC-TCR" International Journal Of Scientific Progress And Research (IJSPR) Volume-11, Number - 03, 2015.
- [4] Syed Estiyak Ali and Mrs. Leena Daniel, "A Fuzzy Logic Approach for Improvement of Power Quality Incorporating FACTS Device, International Journal of Innovative Research in Engineering Applications (IJIREA) Volume 01, Issue 02, December 2015.
- [5] Puranik Sahu, Arun Pachori, "Power Factor Correction Using SVC With Fuzzy Logic Controller", International Journal of Enhanced Research in Science Technology & Engineering, Vol. 2 Issue 4, April-2013, pp: (52-57).
- [6] Srikanth, R.S. Dhekekar "Design, Modeling and Simulation of Fuzzy Controlled SVC" Assistant Professor in the Department of Electrical and Electronics Engineering, National Institute of Technology, Warangal, India
- [7] "Voltage Stability Improvement using Static Var Compensator in Power System" Leonardo Journal of Sciences Issue 14, p. 167-172, January-June 2009.
- [8] R. Mohan Mathur and Rajiv K. Varma, "Thyristor-Based Facts Controllers for Electrical Transmission Systems" 2002.
- [9] P. Anithashalini and T.K. Santhosh, "Electric Supply System With Improved Efficiency Through Power Factor Correction", International Journal of Research and Innovation in Engineering Technology, Volume 02 Issue 03 Pages: 1-7.
- [10] Vladimiro Miranda, "An improved Fuzzy Voltage Inference System for VAR control," IEEE Transactions on Power Systems, vol.22, No.4, November 2000.
- [11] S. Enamul Haque and Nazar H. Malik, "Analysis And Performance of A Fixed Filter-Thyristor Controlled Reactor (FF-TCR) Compensator", IEEE Transactions on Power Systems, Vol. PWRS-2, No.2, May 1987.